

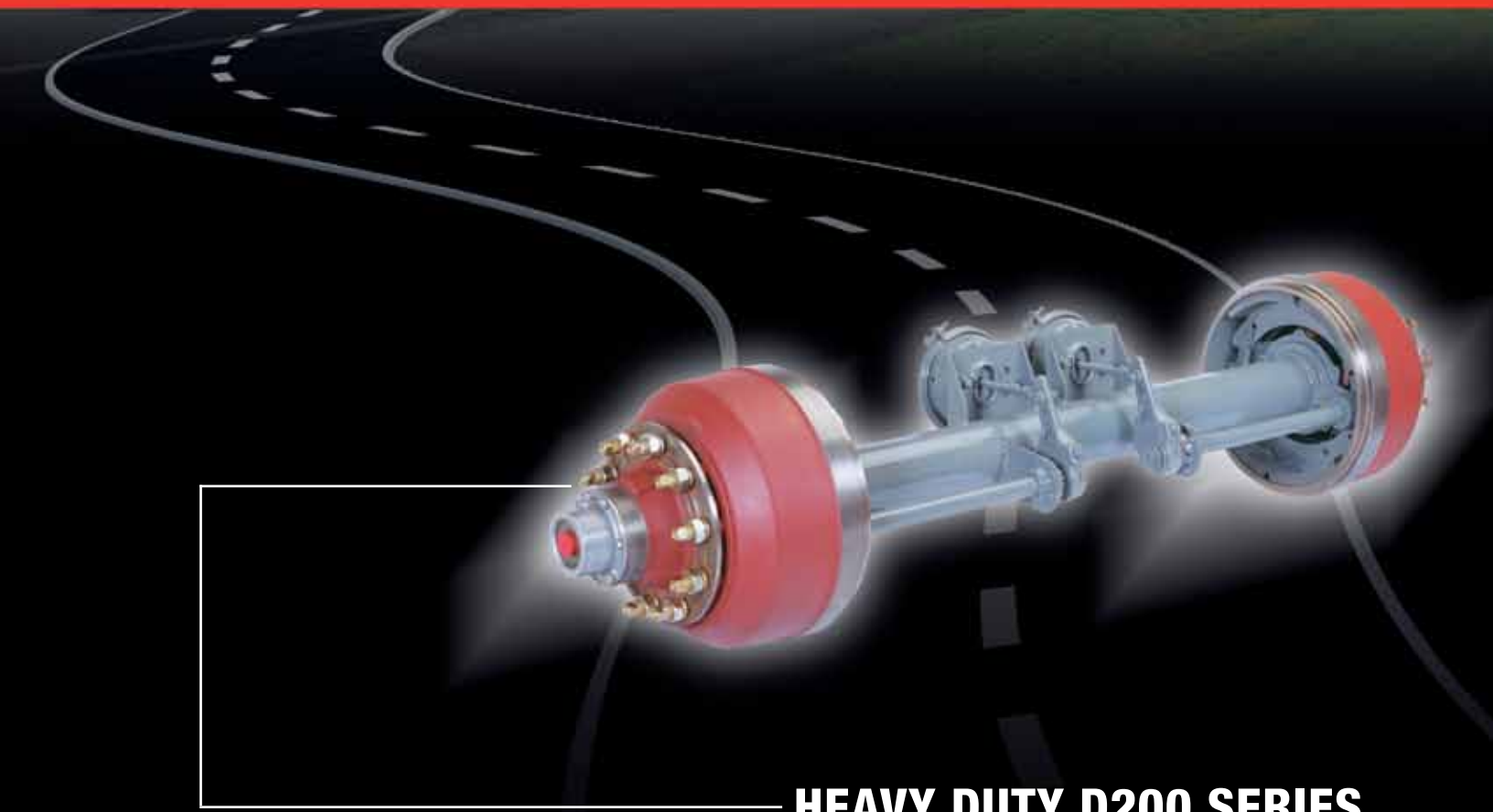

**DEXTER AXLE**

[www.dexteraxle.com](http://www.dexteraxle.com)

**22,500 - 27,500 LBS. CAPACITY**



**HEAVY DUTY D200 SERIES**



This information is intended as a guide for the proper specification and application of Dexter Axle running gear, associated components and accessories.

Dexter offers a full line of trailer axles that can be used in many different applications. When specifying any pre-engineered components such as axles, it is the responsibility of the trailer designer to insure compatibility with the vehicle and all of its sub-systems.

## ***Important Information***

The information presented is meant to assist trailer manufacturers in the specification of their running gear components. Dexter Axle does not warrant that the information given constitutes an approved trailer design or application. Dynamic loading, travel requirements unique to the trailer design, unusual service conditions, trailer configurations, unequal load distribution, hitch or coupler arrangements and towing vehicle suspension characteristics can significantly affect the performance of any trailer axle and/or suspension systems. It remains the responsibility of the trailer manufacturer to evaluate, specify and test their trailer/running gear combination before production and to certify it as such. While the information presented at the time of this writing is current, it is subject to change as designs and components evolve over time.

## ***Disclaimer of Warranty and Limitation of Liability***

All users of this product catalog acknowledge that the information presented is significantly affected by factors within the exclusive knowledge of the user including, among other things, service conditions, trailer configurations, load distributions, hitch and coupler arrangements and tow vehicle suspension characteristics, that the users have independently investigated these factors and have solely relied on those investigations when using this catalog, and that it is the responsibility of the user to adequately specify, evaluate and test its trailer/running gear combinations.

**DEXTER AXLE DISCLAIMS ALL WARRANTIES, WHETHER WRITTEN, ORAL OR IMPLIED, IN FACT OR IN LAW (INCLUDING ANY WARRANTY OF MERCHANTABILITY OR FITNESS FOR A PARTICULAR PURPOSE), ASSOCIATED WITH THE USE OF THE CATALOG AND WITH ANY INFORMATION PRESENTED BY THIS CATALOG.**

Dexter Axle shall not be liable in damages (whether compensatory, punitive, direct, indirect, special, incidental or consequential) to any user of this catalog under contract, tort, strict liability or any other theory of liability, and any user agrees to indemnify and hold Dexter Axle harmless from any and all claims, actions or other proceedings (including attorney fees and court costs) arising out of the use of this catalog to the extent said claims, actions or other proceedings do not arise out of the sole and exclusive negligence of Dexter Axle.

## ***Load Ratings***

The maximum load carrying capacity of any assembly is limited to the lowest load rating of any individual component selected. For instance, the load rating of a pair of wheels may be lower than other axle components selected. If this is the case, the load carrying capacity of the axle assembly is reduced accordingly. As a specific example, if a pair of wheels is rated at 1500 pounds each and is used with other components rated at 4000 pounds per axle, the maximum load capacity is limited to 3000 pounds. If two tires are rated at 1400 pounds each and are used on this assembly, the maximum load carrying capacity is limited to 2800 pounds.



<b>Models and Capacities</b>	
22,500-27,500 Lbs .....	3
Available Axle Tracks .....	3
Brake Performance .....	3
<b>Hubs and Drums</b>	
12¼" x 7½" Brake Size .....	4
16½" x 7" Brake Size .....	7
Cross Reference .....	11
Hubs & Drums; Wheels & Drums .....	11
Bearings, Seals, and Caps .....	12
Anti-Lock Braking Systems (ABS).....	13
<b>Tires &amp; Wheels</b>	
Clearances and Dimensions .....	14
Application Information .....	15
Determining Maximum Spring Centers .....	15
Tires, Wheels & Rims .....	16
<b>Axle/Brake Components</b>	
12¼" x 7½" Brake Size - 'PQ' Style .....	18
16½" x 7" Brake Size - 'Q' Style .....	20
<b>Tandem Air System</b>	
Tandem Air System .....	22
<b>Camshafts</b>	
12¼" x 7½" Brake Size .....	23
16½" x 7" Brake Size .....	24
<b>Air Chambers</b>	
Service Air Chambers .....	25
Spring Brake Air Chambers .....	26
Tandem Axle Configurations .....	27
Off-Road Applications .....	27
Over-the-Highway Applications .....	28
<b>Suspensions</b>	
H-9700 Underslung .....	29
H-9700 Overslung .....	30
<b>Limited Warranty</b>	
Dexter Axle Limited Warranty .....	31

# Models and Capacities



**22,500 – 27,500 LBS.**

Model No.	Beam	Brake	Beam Capacity**	
			Highway w/Leaf Springs	Air Ride Suspension
D-2L12	5" Light Wall	12¼" x 7½"	22,500 Lbs.	n/a +
D-2M12	5" Medium Wall	12¼" x 7½"	25,000 Lbs.	22,500 Lbs.
D-2H12	5" Heavy Wall	12¼" x 7½"	27,500 Lbs.	25,000 Lbs.
D-2L16	5" Light Wall	16½" x 7"	22,500 Lbs.	n/a +
D-2M16	5" Medium Wall	16½" x 7"	25,000 Lbs.	22,500 Lbs.
D-2H16	5" Heavy Wall	16½" x 7"	27,500 Lbs.	25,000 Lbs.

\*\* Allowable use of axle capacity ratings (type of service and track/spring center overhang dimension, etc.) and components vary with application.

+ Light wall tube on models D-2L12 and D-2L16 is not approved for axles equipped with air ride suspensions.

## Available Axle Tracks

Tracks are available from 48" to 124".

## Brake Performance

The following brake models meet or exceed requirements set forth by Federal Motor Vehicle Safety Standards 121 when tested under the following conditions:

Brake Size	Wheel Load *(lbs.)	Rolling Radius (in.)	A.L. Factor (consisting of)
12¼" x 7½"	10,000	15.7	Type 30 A/C 6" Slack Adjuster
16½" x 7"	12,500	19.6	Type 30 A/C 6" Slack Adjuster

\* Wheel Load per wheel end

The permitted use of axles and components, including the capacity ratings that are shown, vary with application and type of service. The capacities indicated for tires, wheels and axles should be used for general guidelines only.

Dexter Axle disclaims all warranties, whether written, oral or implied, in fact or in law (including any warranty of merchantability or fitness for a particular purpose), associated with the use of the manual and with any information presented by this manual.

**MODELS AND CAPACITIES**



# 10 Stud on 8<sup>3</sup>/<sub>4</sub>" Hubs With Inboard Drums

For use with 15" or 17.5" ball seat mounted steel disc wheels

**12<sup>1</sup>/<sub>4</sub>" X 7<sup>1</sup>/<sub>2</sub>" BRAKE SIZE**

**HUBS & DRUMS**

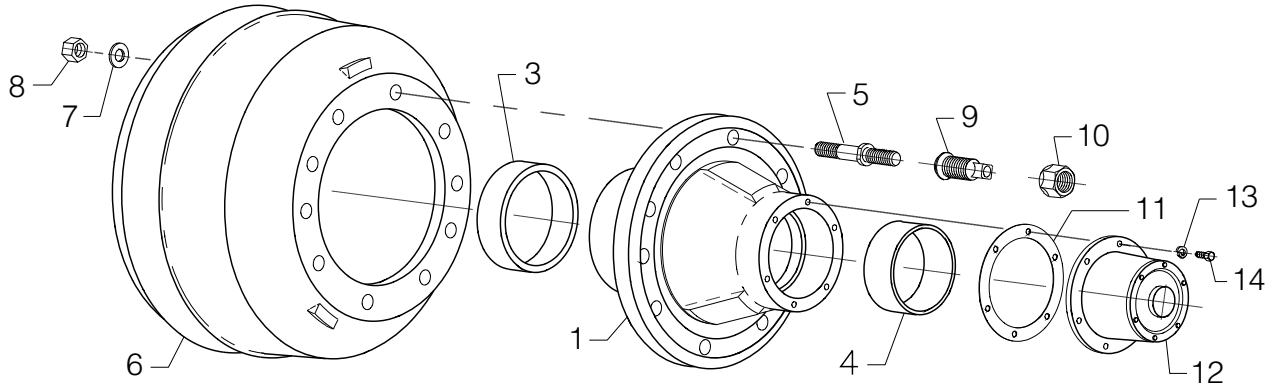

Item	Part No.	Qty	Description	Comments
0	008-277-71	1	LH Assembly Hub & Drum 10 Stud 8 <sup>3</sup> / <sub>4</sub> " BC	Use Ball Seat Mtg. Steel Wheels
0	008-277-70	1	RH Assembly Hub & Drum 10 Stud 8 <sup>3</sup> / <sub>4</sub> " BC	Use Ball Seat Mtg. Steel Wheels
ns	008-277-29	1	LH Assembly Hub & Drum 10 Stud 8 <sup>3</sup> / <sub>4</sub> " BC ABS	Use Ball Seat Mtg. Steel Wheels
ns	008-277-28	1	RH Assembly Hub & Drum 10 Stud 8 <sup>3</sup> / <sub>4</sub> " BC ABS	Use Ball Seat Mtg. Steel Wheels
1	008-277-04	1	LH Assembly Hub 10 Stud 8 <sup>3</sup> / <sub>4</sub> " BC	Includes Items 3-5
1	008-277-05	1	RH Assembly Hub 10 Stud 8 <sup>3</sup> / <sub>4</sub> " BC	Includes Items 3-5
ns	008-277-23	1	LH Assembly Hub 10 Stud 8 <sup>3</sup> / <sub>4</sub> " BC ABS	Includes Items 3-5
ns	008-277-22	1	RH Assembly Hub 10 Stud 8 <sup>3</sup> / <sub>4</sub> " BC ABS	Includes Items 3-5
ns	024-200-01	1	ABS Tone Ring	Included with ABS Hubs
3	031-026-01	1	Inner Bearing Cup (HM218210)	
4	031-027-01	1	Outer Bearing Cup (HM212011)	
5	025-056-02	10	LH Shoulder Stud	
5	025-056-01	10	RH Shoulder Stud	
6	009-040-01	1	Drum 12 <sup>1</sup> / <sub>4</sub> " x 7 <sup>1</sup> / <sub>2</sub> "	
7	005-102-00	10	Washer	
8	006-047-00	10	Hex Nut – Drum Mounting	
9	006-069-02	10	LH Inner Cap Nut	For Steel Disc Wheels
9	006-069-01	10	RH Inner Cap Nut	For Steel Disc Wheels
10	006-070-02	10	LH Outer Cap Nut	
10	006-070-01	10	RH Outer Cap Nut	
11	071-124-00	1	Gasket – Oil Cap	
12	021-038-02	1	Oil Cap (with vent plug)	
13	005-100-00	6	Lock Washer – Oil Cap	
14	007-157-00	6	Cap Screw – Oil Cap	

ns - not shown

## Hub & Drum Dimensional Information

Item	Description	Dimensions
A	Cup to Cup	3.34"
B	Cup to Mounting Face	.81"
C	Cup to End of Drum	10.57"
D	Brake Diameter	12.25"
E	Shoe Brake Width	7.50"
F	Drum Overall Width	10.50"
G	Pilot Diameter	7.12"
H	Bolt Circle	8.75"
I	Bolt Diameter	3/4"
J	Hub Cap Hole Mtg	5/16"
		6 Holes 5.50 BC
Inner Bearing Cup and Cone Overall Stack Thickness		1.575"

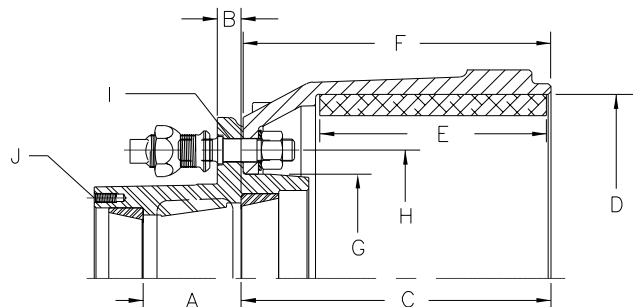

# 8 Stud on 275mm (10.827") Hubs With Outboard Drums



For use with 17.5" or 19.5" 221mm piloted disc wheels

**12 1/4" X 7 1/2" BRAKE SIZE**

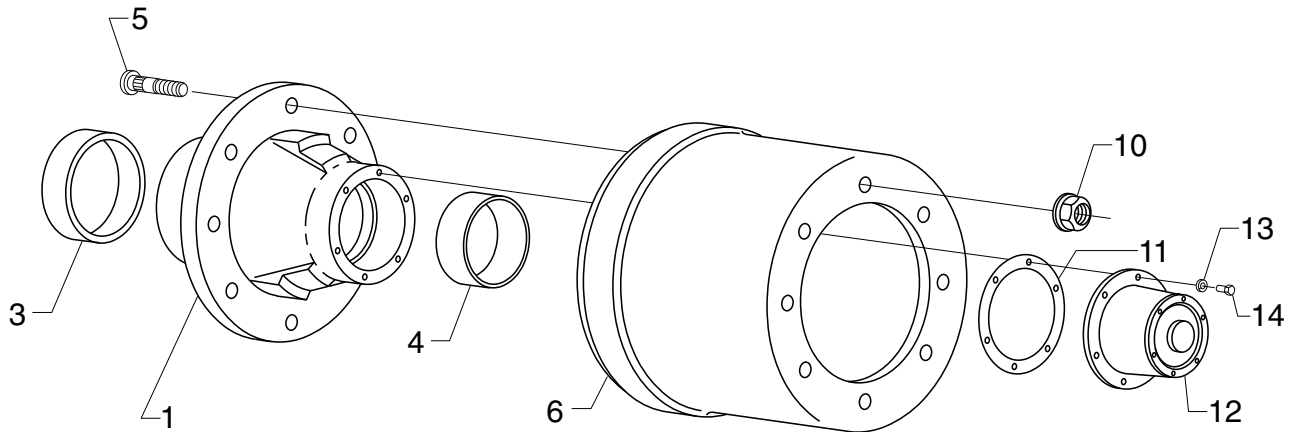

Item	Part No.	Qty	Description	Comments
0	008-396-70	1	Assy Hub & Drum 8 Stud on 275mm BC	Use Pilot Mtg. Steel Wheels
ns	008-396-72	1	Assy Hub & Drum 8 Stud on 275mm BC	Use Pilot Mtg. Aluminum Wheels
ns	008-396-71	1	Assy Hub & Drum 8 Stud on 275mm BC ABS	Use Pilot Mtg. Steel Wheels
ns	008-396-73	1	Assy Hub & Drum 8 Stud on 275mm BC ABS	Use Pilot Mtg. Aluminum Wheels
1	008-396-05	1	Assy Hub 8 Stud on 275mm	Includes Items 3-5 for Steel Wheels
ns	008-396-06	1	Assy Hub 8 Stud on 275mm	Includes Items 3-5 for Aluminum Wheels
ns	008-396-07	1	Assy Hub 8 Stud on 275mm ABS	Included Items 3-5 for Steel Wheels
ns	008-396-08	1	Assy Hub 8 Stud on 275mm ABS	Includes Items 3-5 for Aluminum Wheels
ns	024-200-01	1	ABS Tone Ring	Included with ABS Hubs
3	031-026-01	1	Inner Bearing Cup (HM218210)	
4	031-027-01	1	Outer Bearing Cup (HM212011)	
5	007-194-00	8	Stud, Press-In M22 x 1.5	2.47" Stud Length for Steel Wheels
5	007-195-00	8	Stud, Press-In M22 x 1.5	3.32" Stud Length for Aluminum Wheels
6	009-116-01	1	Drum 12 1/4" x 7 1/2"	
10	006-118-00	8	Swivel Flange Nut	
11	071-124-00	1	Gasket - Oil Cap	
12	021-038-02	1	Oil Cap (with vent plug)	
13	005-100-00	6	Lock Washer - Oil Cap	
14	007-157-00	6	Cap Screw - Oil Cap	

ns - not shown

## Hub & Drum Dimensional Information

Item	Description	Dimensions
A	Cup to Cup	3.34"
B	Cup to Mounting Face	.75"
C	Cup to End of Drum	10.43"
D	Brake Diameter	12.25"
E	Shoe Brake Width	7.50"
F	Drum Overall Width	11.22"
G	Pilot Diameter (Drum)	9.00"
H	Bolt Circle	275mm (10.827")
I	Bolt Diameter	M22 x 1.5
J	Hub Cap Hole Mtg	5/16"
		6 Holes 5.50 BC
Inner Bearing Cup and Cone Overall Stack Thickness		1.575"

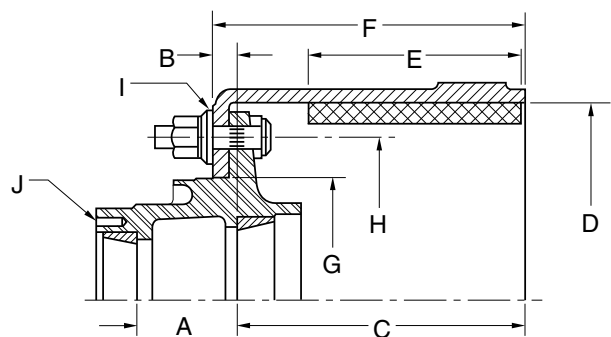

**HUBS & DRUMS**



## 3-Spoke Cast Wheels

For use with 15" or 17.5" demountable rims

12 1/4" X 7 1/2" BRAKE SIZE

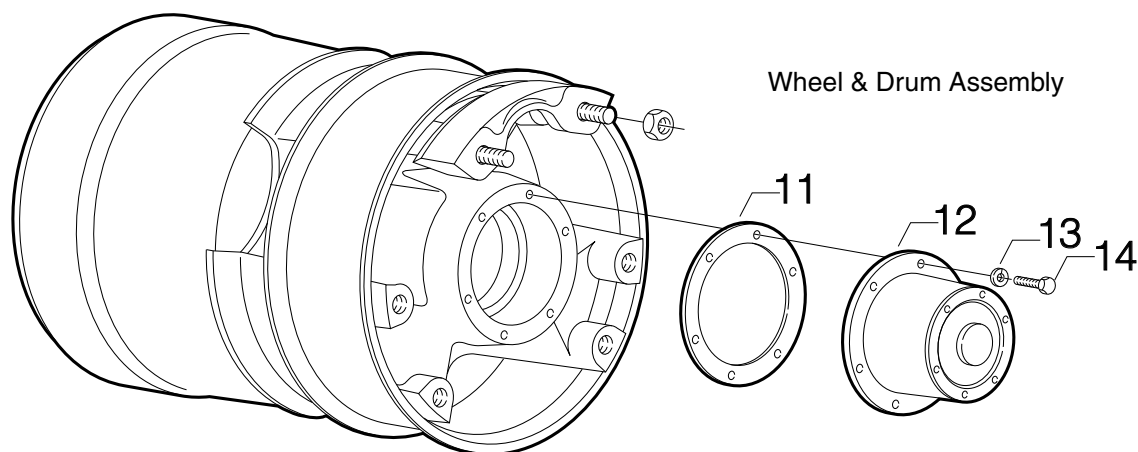

Item	Part No.	Qty	Description
	008-269-70	1	Wheel & Drum Assembly - Webb 70159-CCA
	008-269-71	1	Wheel & Drum Assembly - Dayton Walther 48-14054-054
	008-269-75	1	Wheel & Drum Assembly - Gunite 5785-1
	008-269-76	1	Wheel & Drum Assembly - KIC 001-70003H
	008-269-72	1	ABS Wheel & Drum Assembly - Dayton Walther 48-15613-056
	008-269-73	1	ABS Wheel & Drum Assembly - Webb 70159 CCAT80
	008-269-74	1	ABS Wheel & Drum Assembly - Gunite 5785-2
	008-269-77	1	ABS Wheel & Drum Assembly - KIC 001-70003TH
11	071-124-00	1	Gasket - Oil Cap
12	021-038-02	1	Oil Cap (with vent plug)
13	005-100-00	6	Lock Washer - Oil Cap
14	007-157-00	6	Cap Screw - Oil Cap

HUBS & DRUMS

### Hub & Drum Dimensional Information

Item	Description	Dimensions
A	Cup to Cup	3.34"
B	Cup to Centerline Track	1.36" (w/4.00" spacer)
C	Cup to End of Drum	10.57"
D	Brake Diameter	12.25"
E	Shoe Brake Width	7.50"
F	Drum Overall Width	9.07"
G	Pilot Diameter	8.50"
H	Bolt Circle	10.00"
I	Bolt Diameter	5/16" (6 holes)
J	Hub Cap Hole Mtg	5/16"
		6 Holes 5.50 BC
K	Spacer	15" x 4"
	Inner Bearing Cup and Cone Overall Stack Thickness	1.575"

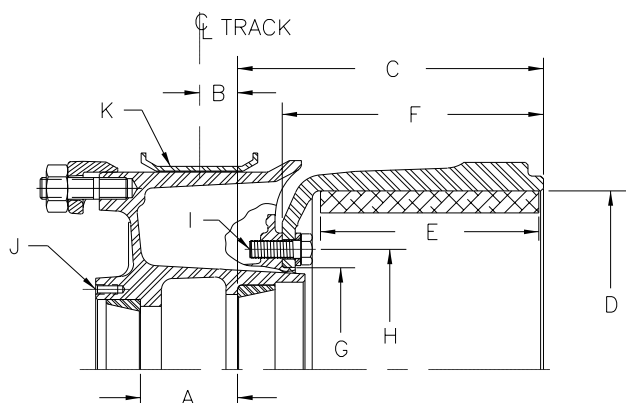

Dimensions listed are referenced for Webb part only. Other cast wheel suppliers' dimensions may be slightly different. Check with supplier.

# 10 Stud on 11¼" Hubs With Inboard Drums



**16½" X 7" BRAKE SIZE**

For use with 20", 22.5" or 24.5" ball seat mounted steel disc wheels

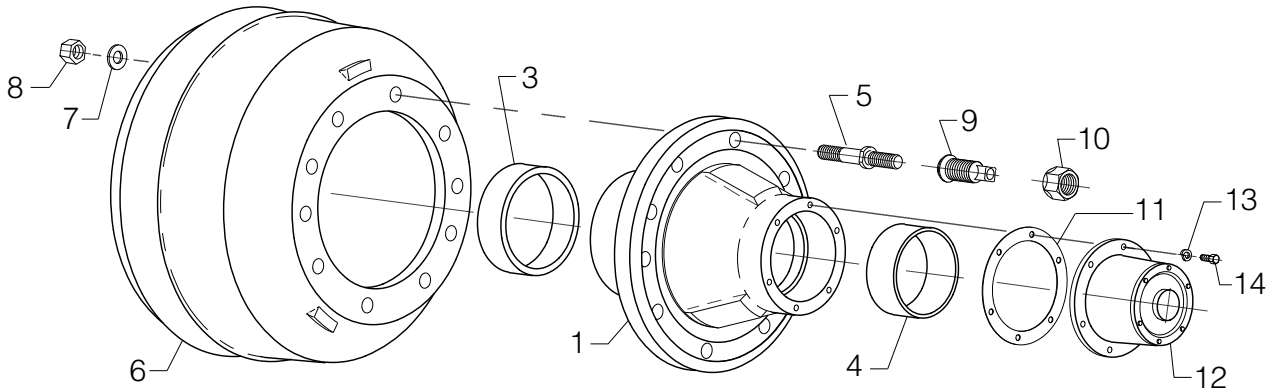

Item	Part No.	Qty	Description	Comments
0	008-279-71	1	LH Assembly Hub & Drum 10 Stud 11¼" BC	Use Ball Seat Mtg. Steel Wheels
0	008-279-70	1	RH Assembly Hub & Drum 10 Stud 11¼" BC	Use Ball Seat Mtg. Steel Wheels
1	008-279-04	1	LH Assembly Hub 10 Stud 11¼" BC	Includes Items 3-5
1	008-279-05	1	RH Assembly Hub 10 Stud 11¼" BC	Includes Items 3-5
3	031-026-01	1	Inner Bearing Cup (HM218210)	
4	031-027-01	1	Outer Bearing Cup (HM212011)	
5	025-056-02	10	LH Shoulder Stud	
5	025-056-01	10	RH Shoulder Stud	
6	009-042-01	1	Drum 16½" x 7"	
7	005-102-00	10	Washer	
8	006-047-00	10	Hex Nut - Drum Mounting	
9	006-069-02	10	LH Inner Cap Nut	For Steel Disc Wheels
9	006-069-01	10	RH Inner Cap Nut	For Steel Disc Wheels
10	006-070-02	10	LH Outer Cap Nut	
10	006-070-01	10	RH Outer Cap Nut	
11	071-124-00	1	Gasket - Oil Cap	
12	021-038-02	1	Oil Cap (with vent plug)	
13	005-100-00	6	Lock Washer - Oil Cap	
14	007-157-00	6	Cap Screw - Oil Cap	

ns - not shown

## Hub & Drum Dimensional Information

Item	Description	Dimensions
A	Cup to Cup	3.34"
B	Cup to Mounting Face	.81"
C	Cup to End of Drum	9.89"
D	Brake Diameter	16.50"
E	Shoe Brake Width	7.00"
F	Drum Overall Width	9.58"
G	Pilot Diameter	9.44"
H	Bolt Circle	11.25"
I	Bolt Diameter	¾"
J	Hub Cap Hole Mtg	⅝"
		6 Holes 5.50 BC
Inner Bearing Cup and Cone Overall Stack Thickness		1.575"

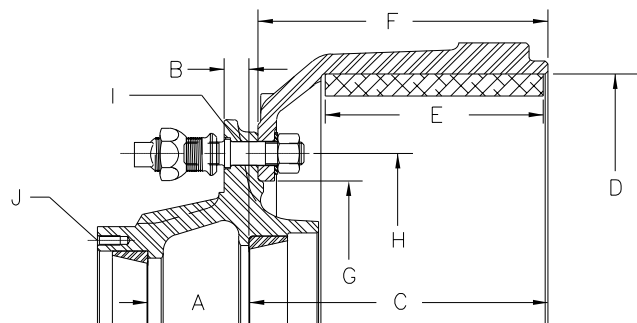

**HUBS & DRUMS**



# 10 Stud on 11 1/4" Hubs With Outboard Drums



For use with 20", 22.5" or 24.5" ball seat mounted steel disc wheels

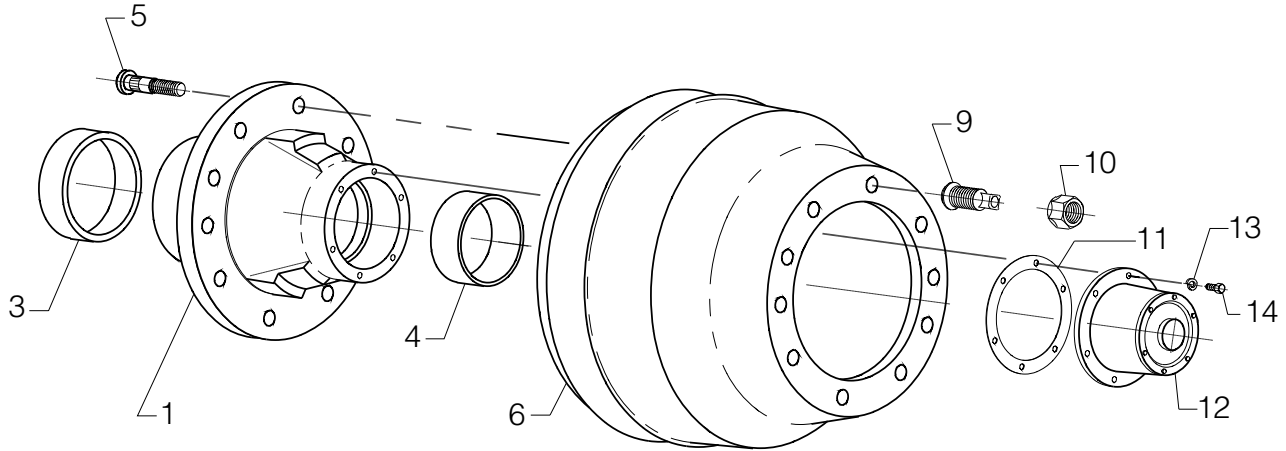

Item	Part No.	Qty	Description	Comments
0	008-290-80	1	LH Assembly Hub & Drum 10 Stud 11 1/4" BC	Use Ball Seat Mtg. Wheels
0	008-290-79	1	RH Assembly Hub & Drum 10 Stud 11 1/4" BC	Use Ball Seat Mtg. Wheels
ns	008-290-82	1	LH Assembly Hub & Drum 10 Stud 11 1/4" BC ABS	Use Ball Seat Mtg. Wheels
ns	008-290-81	1	RH Assembly Hub & Drum 10 Stud 11 1/4" BC ABS	Use Ball Seat Mtg. Wheels
1	008-290-68	1	LH Assembly Hub 10 Stud 11 1/4" BC	Includes Items 3-5
1	008-290-67	1	RH Assembly Hub 10 Stud 11 1/4" BC	Includes Items 3-5
ns	008-290-70	1	LH Assembly Hub 10 Stud 11 1/4" BC ABS	Includes Items 3-5
ns	008-290-69	1	RH Assembly Hub 10 Stud 11 1/4" BC ABS	Includes Items 3-5
ns	024-200-01	1	ABS Tone Ring	Included with ABS Hubs
3	031-026-01	1	Inner Bearing Cup (HM218210)	
4	031-027-01	1	Outer Bearing Cup (HM212011)	
5	007-242-01	10	LH Stud, Press-In	1.38" Stud Stand Out Length
5	007-242-00	10	RH Stud, Press-In	1.38" Stud Stand Out Length
6	009-043-03	1	Drum 16 1/2" x 7"	
9	006-069-02	10	LH Inner Cap Nut	For Steel Disc Wheels
9	006-069-01	10	RH Inner Cap Nut	For Steel Disc Wheels
9	006-124-02	10	LH Inner Cap Nut	For Aluminum Disc Wheels
9	006-124-01	10	RH Inner Cap Nut	For Aluminum Disc Wheels
10	006-070-02	10	LH Outer Cap Nut	
10	006-070-01	10	RH Outer Cap Nut	
11	071-124-00	1	Gasket – Oil Cap	
12	021-038-02	1	Oil Cap (with vent plug)	
13	005-100-00	6	Lock Washer – Oil Cap	
14	007-157-00	6	Cap Screw – Oil Cap	

ns - not shown

## Hub & Drum Dimensional Information

Item	Description	Dimensions
A	Cup to Cup	3.34"
B	Cup to Mounting Face	.73"
C	Cup to End of Drum	9.87"
D	Brake Diameter	16.50"
E	Shoe Brake Width	7.00"
F	Drum Overall Width	10.60"
G	Pilot Diameter	8.78"
H	Bolt Circle	11.25"
I	Bolt Diameter	3/4"
J	Hub Cap Hole Mtg	5/16"
		6 Holes 5.50 BC
Inner Bearing Cup and Cone Overall Stack Thickness		1.575"

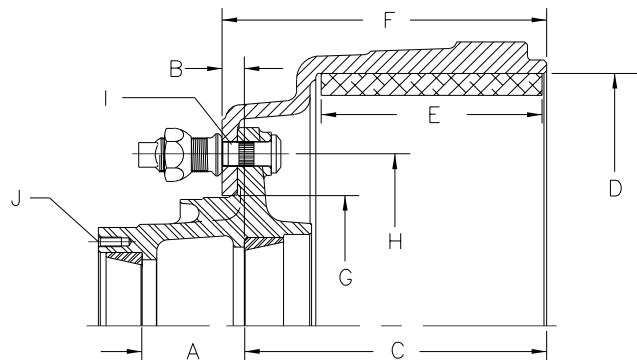

# 10 Stud on 285.75mm (11.25") Hub Piloted With Outboard Drums



**16 1/2" X 7" BRAKE SIZE**

For use with 20", 22.5" or 24.5" 220mm piloted disc wheels

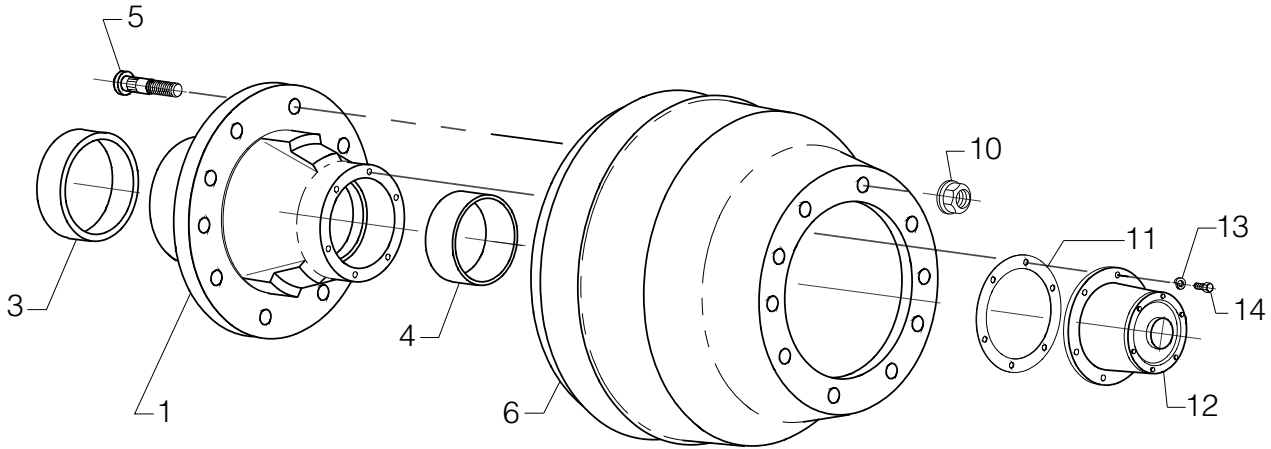

Item	Part No.	Qty	Description	Comments
0	008-290-32	1	Assy Hub & Drum 10 Stud 285.75mm BC	Use Pilot Mtg. Steel Wheels
ns	008-290-34	1	Assy Hub & Drum 10 Stud 285.75mm BC	Use Pilot Mtg. Aluminum Wheels
ns	008-290-33	1	Assy Hub & Drum 10 Stud 285.75mm BC ABS	Use Pilot Mtg. Steel Wheels
ns	008-290-35	1	Assy Hub & Drum 10 Stud 285.75mm BC ABS	Use Pilot Mtg. Aluminum Wheels
1	008-290-13	1	Assy Hub 10 Stud 285.75mm	Includes Items 3-5 for Steel Wheels
ns	008-290-14	1	Assy Hub 10 Stud 285.75mm	Includes Items 3-5 for Aluminum Wheels
ns	008-290-16	1	Assy Hub 10 Stud 285.75mm ABS	Includes Items 3-5 for Steel Wheels
ns	008-290-17	1	Assy Hub 10 Stud 285.75mm ABS	Includes Items 3-5 for Aluminum Wheels
ns	024-200-01	1	ABS Tone Ring	Included with ABS hubs
3	031-026-01	1	Inner Bearing Cup (HM218210)	
4	031-027-01	1	Outer Bearing Cup (HM212011)	
5	007-194-00	10	Stud, Press-In M22 x 1.5	2.47" Stud Length for Steel Wheels
5	007-195-00	10	Stud, Press-In M22 x 1.5	3.32" Stud Length for Aluminum Wheels
6	009-043-03	1	Drum 16 1/2" x 7"	
10	006-118-00	10	Swivel Flange Nut	
11	071-124-00	1	Gasket - Oil Cap	
12	021-038-02	1	Oil Cap (with vent plug)	
13	005-100-00	6	Lock Washer - Oil Cap	
14	007-157-00	6	Cap Screw - Oil Cap	

ns - not shown

## Hub & Drum Dimensional Information

Item	Description	Dimensions
A	Cup to Cup	3.34"
B	Cup to Mounting Face	.73"
C	Cup to End of Drum	9.87"
D	Brake Diameter	16.50"
E	Shoe Brake Width	7.00"
F	Drum Overall Width	10.60"
G	Pilot Diameter (Drum)	8.78"
H	Bolt Circle	285.75mm (11.25")
I	Bolt Diameter	M22 x 1.5
J	Hub Cap Hole Mtg	5/16"
		6 Holes 5.50 BC
Inner Bearing Cup and Cone Overall Stack Thickness		1.575"

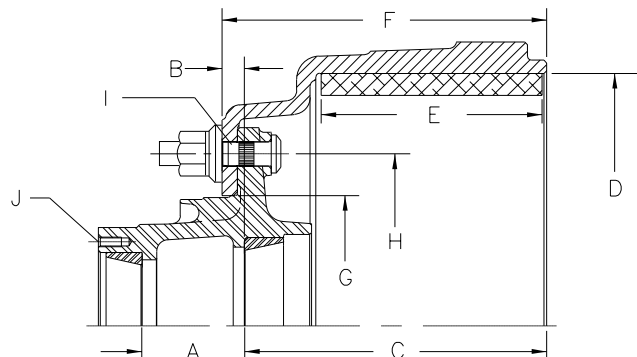

**HUBS & DRUMS**

## 5-Spoke Cast Wheels



For use with 20" or 22.5" demountable rims

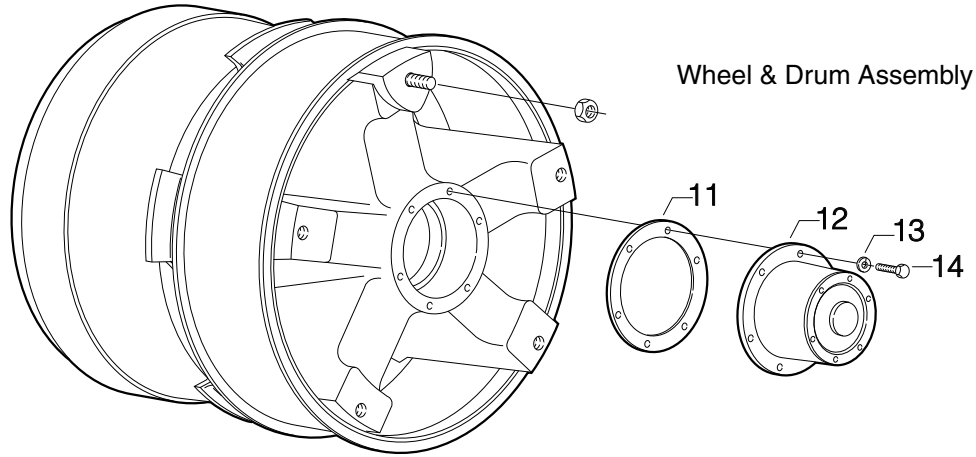

Item	Part No.	Qty	Description
	008-267-71	1	Wheel & Drum Assembly - Gunite 5763-1
	008-267-72	1	Wheel & Drum Assembly - Webb 75209-GCA
	008-267-76	1	Wheel & Drum Assembly - KIC 001-75207H
	008-267-74	1	ABS Wheel & Drum Assembly - Gunite 5763-2
	008-267-77	1	ABS Wheel & Drum Assembly - KIC 001-75207TH
11	071-124-00	1	Gasket - Oil Cap
12	021-038-02	1	Oil Cap (with vent plug)
13	005-100-00	6	Lock Washer - Oil Cap
14	007-157-00	6	Cap Screw - Oil Cap

### Hub & Drum Dimensional Information

Item	Description	Dimensions
A	Cup to Cup	3.34"
B	Cup to Centerline Track	1.36" (w/4.00" spacer)
C	Cup to End of Drum	9.90"
D	Brake Diameter	16.50"
E	Shoe Brake Width	7.00"
F	Drum Overall Width	8.38"
G	Pilot Diameter	9.44"
H	Bolt Circle	11.00"
I	Bolt Diameter	5/8"
J	Hub Cap Hole Mtg	5/16"
		6 Holes 5.50 BC
K	Spacer	20" x 4"
Inner Bearing Cup and Cone Overall Stack Thickness		1.575"

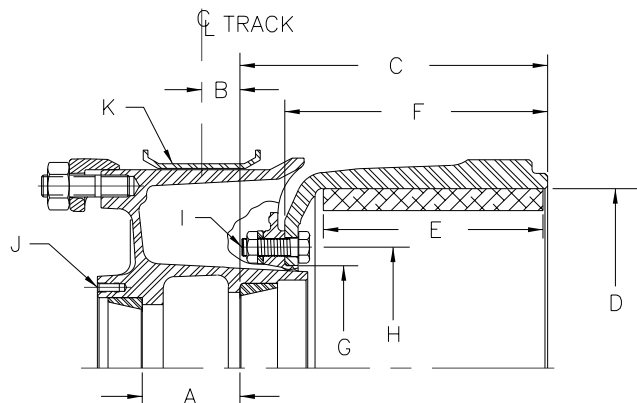

Dimensions listed are referenced for Webb part only. Other cast wheel suppliers' dimensions may be slightly different. Check with supplier.

# Hubs & Drums; Wheels & Drums



**CROSS REFERENCE**

Description	Dexter	Webb	Erie	Dayton Walther	KIC	Gunite
Assembly 8 on 275mm BC; Outboard 12¼" Brake*	008-396-70	20271CW4	n/a	n/a	001-00133	n/a
Assembly 8 on 275mm BC; Outboard 12¼" Brake-ABS*	008-396-71	20271CW4T	n/a	n/a	001-00133T	n/a
Assembly 8 on 275mm BC; Outboard 12¼" Brake <sup>+</sup>	008-396-72	20271CW6	n/a	n/a	001-00133L	n/a
Assembly 8 on 275mm BC; Outboard 12¼" Brake-ABS <sup>+</sup>	008-396-73	20271CW6T	n/a	n/a	001-00133LT	n/a
Assembly 10 on 8¾" BC RH; Inboard 12¼" Brake*	008-277-70	10519CLMR	n/a	n/a	001-10511	n/a
Assembly 10 on 8¾" BC RH; Inboard 12¼" Brake-ABS*	008-277-28	10519CLMRT	n/a	n/a	001-10511T	n/a
Assembly 10 on 8¾" BC LH; Inboard 12¼" Brake*	008-277-71	10519CLML	n/a	n/a	001-10512	n/a
Assembly 10 on 8¾" BC LH; Inboard 12¼" Brake-ABS*	008-277-29	10519CLMLT	n/a	n/a	001-10512T	n/a
Assembly 15" 3-Spoke; 12¼" Brake	008-269-xx	70159CCA	950-2700-10	48-14054-054	001-70003H	5785-1
Assembly 15" 3-Spoke; 12¼" Brake-ABS	008-269-xx	70159CCAT80	950-2700-10-A	48-15613-056	001-70003TH	5785-2
Assy 10 on 11¼" BC RH; 9.44 Pilot Inboard 16½" Brake*	008-279-70	10019 BE_R	704-2760 RH	n/a	n/a	5559-RH1
Assy 10 on 11¼" BC LH; 9.44 Pilot Inboard 16½" Brake*	008-279-71	10019 BE_L	704-2760 LH	n/a	n/a	5559-LH1
Assy 10 on 11¼" BC RH; 8.78 Pilot Outboard 16½" Brake*	008-290-79	20231UQ_R	Call Erie sales office	n/a	001-00126	n/a
Assy 10 on 11¼" BC RH; 8.78 Pilot Outboard 16½" Brake-ABS*	008-290-81	20231UQ_RT	814-452-6431 for assistance.	n/a	001-00126T	n/a
Assy 10 on 11¼" BC LH; 8.78 Pilot Outboard 16½" Brake*	008-290-80	20231UQ_L		n/a	001-00127	n/a
Assy 10 on 11¼" BC LH; 8.78 Pilot Outboard 16½" Brake-ABS*	008-290-82	20231UQ_LT		n/a	001-00127T	n/a
Assy 10 on 285.75mm BC; 8.78 Pilot Outboard 16½" Brake*	008-290-32	Heavy Duty 20231UQ4 or Extra Hvy 20231UH4	706-2764-5 with 5324 Studs for Steel Wheels	n/a	Heavy Duty 001-00125	n/a
Assy 10 on 285.75mm BC; 8.78 Pilot Outboard 16½" Brake-ABS*	008-290-33	Heavy Duty 20231UQ4T or Extra Hvy 20231UH4T	706-2764-5-A with 5424 Studs for Steel Wheels	n/a	Heavy Duty 001-0125T	n/a
Assy 10 on 285.75mm BC; 8.78 Pilot Outboard 16½" Brake <sup>+</sup>	008-290-34	Heavy Duty 20231UQ6 or Extra Hvy 20231UH6	706-2764-5-A with 5322 Studs for Aluminum Wheels	n/a	Heavy Duty 001-0125L	n/a
Assy 10 on 285.75mm BC; 8.78 Pilot Outboard 16½" Brake-ABS <sup>+</sup>	008-290-35	Heavy Duty 20231UQ6T or Extra Hvy 20231UH6T	706-2764-5-A with 5322 Studs for Aluminum Wheels	n/a	Heavy Duty 001-0125LT	n/a
Assembly 20" 5-Spoke; 16½" Brake	008-267-xx	75209GCA	904-2738-1	48-14018-051	001-75207H	5763-1
Assembly 20" 5-Spoke; 16½" Brake-ABS	008-267-xx	75209GCAT	904-2738-1-A	n/a	001-75207TH	5763-2

xx = See Hubs & Drums section for part number that varies with manufacturer.

The following listed part numbers have a drum pilot diameter of 8.53". These are obsolete and are available as service parts only, not to be used for new construction. For new assemblies having 8.78" diameter drum pilot, see the above part numbers 008-290-79; -80; -81; -82.

Description	Dexter	Webb	Erie	Dayton Walther	KIC	Gunite
Assy 10 on 11¼" BC RH; 8.53 Pilot Outboard 16½" Brake*	008-290-20	10209FRMR	705-2764 RH	n/a	n/a	5631-RH1
Assy 10 on 11¼" BC RH; 8.53 Pilot Outboard 16½" Brake-ABS*	008-290-57	10209FRMRT	705-2764 RH-A	n/a	n/a	n/a
Assy 10 on 11¼" BC LH; 8.53 Pilot Outboard 16½" Brake*	008-290-21	10209FRML	705-2764 LH	n/a	n/a	5631-LH1
Assy 10 on 11¼" BC LH; 8.53 Pilot Outboard 16½" Brake-ABS*	008-290-58	10209FRMLT	705-2764 LH-A	n/a	n/a	n/a

### Interchange Reference Information

The interchange reference information listed herein is based on the best available information at the time of publication and is to be used as a guide only. Although every care has been taken in order to insure the accuracy of these interchanges, Dexter does not assume any liability for errors, changes, omissions, or for harm resulting therefrom. It is recommended that all parts be thoroughly checked for proper form, fit, and function prior to installation and usage to determine interchangeability.

- \* Steel Wheels
- + Aluminum Wheels

**HUBS & DRUMS**

# Bearings, Seals, and Caps



**CROSS REFERENCE**

Type	Description	Dexter Part No.
Bearings		
	Inner Bearing Cone (HM218248)	031-026-02
	Outer Bearing Cone (HM212049)	031-027-02
Oil Seal Unitized		
	National B-370025-BGR (Dexter standard)	010-055-01
	Midland Mechanics Barrier 755400	010-055-02
	Stemco Guardian 307-0743	010-055-03
	Stemco 373-0143 Unitized	010-055-04
	Dichtomatik OB4660099	010-055-09
Oil Cap		
	Stemco 343-4009	021-038-01
	APT A-4010	021-038-02
Grease Cap		
		021-046-00

**HUBS & DRUMS**

# Anti-Lock Braking Systems (ABS)



March 1, 1998, the National Highway Traffic Safety Administration (NHTSA) passed a law that required all new trailers with air actuated brakes to have anti-lock braking capability for any vehicle that falls under FMVSS121.

Dexter's D200 series axles are offered with the ABS sensors (all 90° sensors) from the following ABS system manufacturers:

<b>Manufacturer</b>	<b>Dexter PN</b>	<b>Manufacturers PN</b>
Haldex	097-003-00	36409001
Meritor - Wabco	097-007-00	441-032-808-0

It is recommended that the Electronic Control Unit (ECU) purchased for the trailer (not supplied by Dexter Axle) be from the same manufacturer as the sensor.

Information about the various ECU's and other products offered by the manufacturers may be found by contacting the manufacturer or one of their distributors:

## **Haldex**

10707 NW Airworld Drive  
Kansas City, MO 64153  
Telephone: (816) 891-2470  
Customer Service: (800) 643-2374  
[www.hbsna.com](http://www.hbsna.com)

## **Meritor - Wabco**

2135 West Maple Road  
Troy, MI 48084  
Customer Service: (800) 535-5560  
[www.meritorwabco.com](http://www.meritorwabco.com)



Spring Center – for absolute maximum refer to calculation procedures.  
 (T – 34.50" will satisfy most needs)

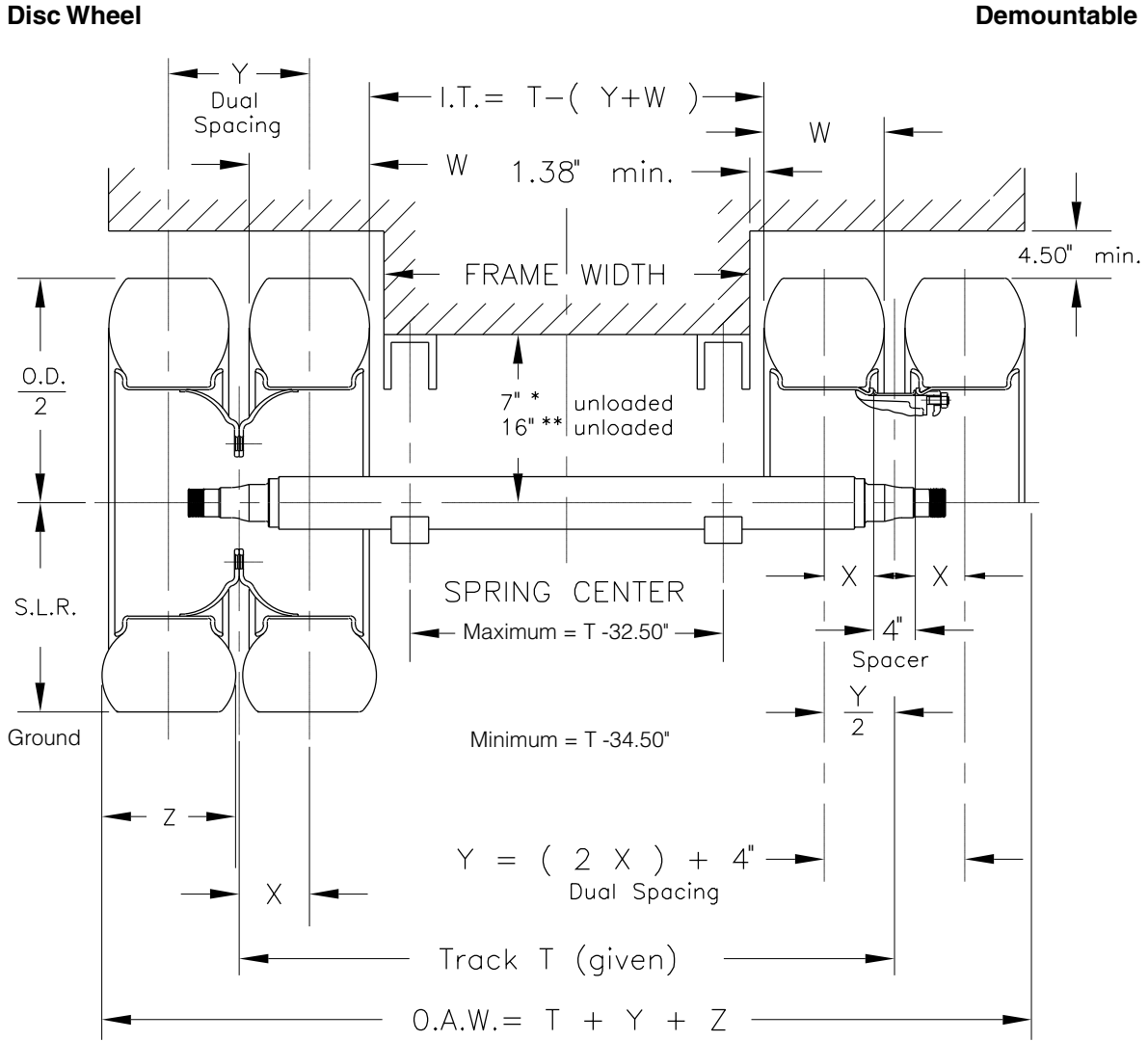

\* Underslung Using 3/4" seat height and 3 leaf – 354-00 spring (standard Dexter HAP Kits)  
 \*\* Overslung

# Determining Maximum Spring Centers for 22.5K – 27.5K Axles



1. Typical over-the-road 96" wide semi-trailers with leaf spring suspensions are equipped with axles having 71" or 71½" axle track and either 38" or 39" spring centers. 102" wide trailers use axles having 77" or 77½" axle track and either 44" or 45" spring centers.
2. Axle track should be the widest possible with the overall width of the outer dual tires not exceeding the maximum trailer width of either 96" or 102" as specified by law. Verify with State and Federal laws for the type of roads the trailer is traveling.
3. Spring centers should be placed as wide as possible to aid in resisting trailer rolling movement - side-to-side sway. Maximum spring center is governed by either the distance between drums or the distance between the inner dual tires of a given axle. Spring centers less than the minimum specified will reduce axle carrying capacity.
4. Begin by selecting appropriate dual tire capacity and rim or wheel capacity to adequately haul the load for which the trailer was designed.

## Factor 1 - Distance between drums

- A. Determine the hub group required to mate with the tires, rims or wheels previously selected.
- B. From the hub group section of this catalog, locate the proper hub & drum or wheel & drum.
- C. **For Demountable Rims.** Obtain the B and C dimensions for your selected hub group in this catalog, add them together, then multiply by 2. Subtract this number from your track dimension to obtain the dimension between drums.
- D. **For Disc Wheels.** Obtain the B and C dimensions for your selected hub group in this catalog. Next, determine the wheel's disc thickness at the mounting area. Add these three figures together, then multiply by 2. Subtract this number from your track dimension to obtain the dimension between drums.

## Factor 2 - Distance between inner tires

5. Obtain the tire width dimension for the tires previously selected. Dimensions shown in this catalog may vary from manufacturer to manufacturer. Check your tire manufacturer's latest tire catalog to be sure of the dimensions.

- A. **For Demountable Rims.** From the following pages, obtain the W dimension (width of your selected tire) and the Y dimension (dual rim spacing of appropriate rims for your selected tire) and add them together. Subtract this number from your track dimension to obtain the dimension between the inner dual tire set.
  - B. **For Disc Wheels.** From the previous pages, obtain the W dimension (width of your selected tire) and the Y dimension (dual wheel spacing of appropriate wheels for your selected tire) and add them together. Subtract this number from your track dimension to obtain the dimension between the inner dual tire set.
6. Compare these two calculated numbers – Factor 1 and Factor 2 – and select the smallest (narrowest) of the two.
  7. Subtract 2.75 from the above selected smallest number. This should be your outside to outside widest frame width for your given track. The minimum frame clearance per side is 1.375, then is multiplied by 2 to get 2.75.
  8. Determine the width of your suspension system hangers, typically 6.00 inches for H-9700 Hutch suspension. If other than Hutch H-9700 are used, determine the location of your selected suspension system's hangers and where they are to be positioned laterally on the trailer frame member. Consult the manufacturer of your suspension system if the location is not detailed in their catalog. Determine the distance from frame width to centerline of suspension attachment to the axle beam tube relative to this hanger position.
  9. Subtract this number from outside frame width to obtain the maximum spring center allowed.





Brake Size	Tire Size (Load Range)	Design Rim Width	**Dual Tire Capacity per Tire (lbs.)	Max Inflation P.S.I	O.D.*	Tire Width W	Loaded Section Width Z	S.L.R.*	Min. Dual Spacing
12¼"	10R17.5 (H)	6.75HC	4410	115	33.7	9.4	10.4	15.6	10.9
12¼"	215/75R17.5 (H)	6.75HC	4540	125	30.6	8.4	9.3	14	9.6
12¼"	235/75R17.5 (H)	6.75HC	5675	125	31.8	9.2	10.1	14.5	10.3
12¼"	245/70R19.5 (G)	6.75	4375	100	33.0	10.2	11.0	15.3	11.0
12¼"	265/70R19.5 (G)	6.75	5070	120	34.0	10.3	11.2	15.9	11.6
16½"	255/70R22.5 (H)	7.50	5070	115	36.6	9.8	10.6	17.1	11.3
16½"	295/75R22.5 (G)	8.25	5675	100	40.2	11.2	12.2	18.8	11.2
16½"	11R22.5 (G)	8.25	5750	105	41.5	10.8	11.9	19.4	12.5
16½"	11R22.5 (H)	8.25	5800	110	41.5	10.8	11.9	19.4	12.5
16½"	11R24.5 (G)	8.25	6000	105	43.5	10.8	11.9	20.4	12.5
16½"	11R24.5 (H)	8.25	6170	110	43.5	10.8	11.9	20.4	12.5

\* Dimensions shown may vary slightly from manufacturer to manufacturer

\*\* Dual Rating



Rim Contour	Description	Wheel/Rim Capacity Each (lbs.)	Max. Inflation (P.S.I.)	Mtg. Hole Pattern	Wheel Center Disc Thickness	Offset X	Dual Spacing Y
17.5 x 6.75 HC	Rim	4805	125	Demountable 4" Spacer	n/a	3.90"	11.80"
17.5 x 6.75 HC	Steel Wheel	5070	125	10 Hole 8.75" BC 6.50" Bore Ball Seat	.42"	6.19"	12.38"
17.5 x 6.75 HC	Steel Wheel	5355	125	8 Hole 275mm BC 221mm Bore Pilot Mounting	.437"	5.60"	11.20"
19.5 x 6.75 RW	Steel Wheel	5000	120	8 Hole 275mm BC 221mm Bore Pilot Mounting	.437"	5.60"	11.2"
22.5 x 7.50	Steel Wheel	6610	120	10 Hole 11¼" BC 8.72" Bore Ball Seat	.437"	6.44"	12.88"
22.5 x 8.25	Steel Wheel	7400	120	10 Hole 11¼" BC 8.72" Bore Ball Seat	.437"	6.62"	13.25"
22.5 x 8.25	Steel Wheel	7400	120	10 Hole 285.75mm BC 220mm Bore Pilot Mounting	.437"	6.62"	13.25"
24.5 x 8.25	Steel Wheel	7300	120	10 Hole 285.75mm BC 220mm Bore Pilot Mounting	.437"	6.62"	13.25"



# Axle/Brake Components

**12 1/4" X 7 1/2" BRAKE SIZE**

'PQ' Style

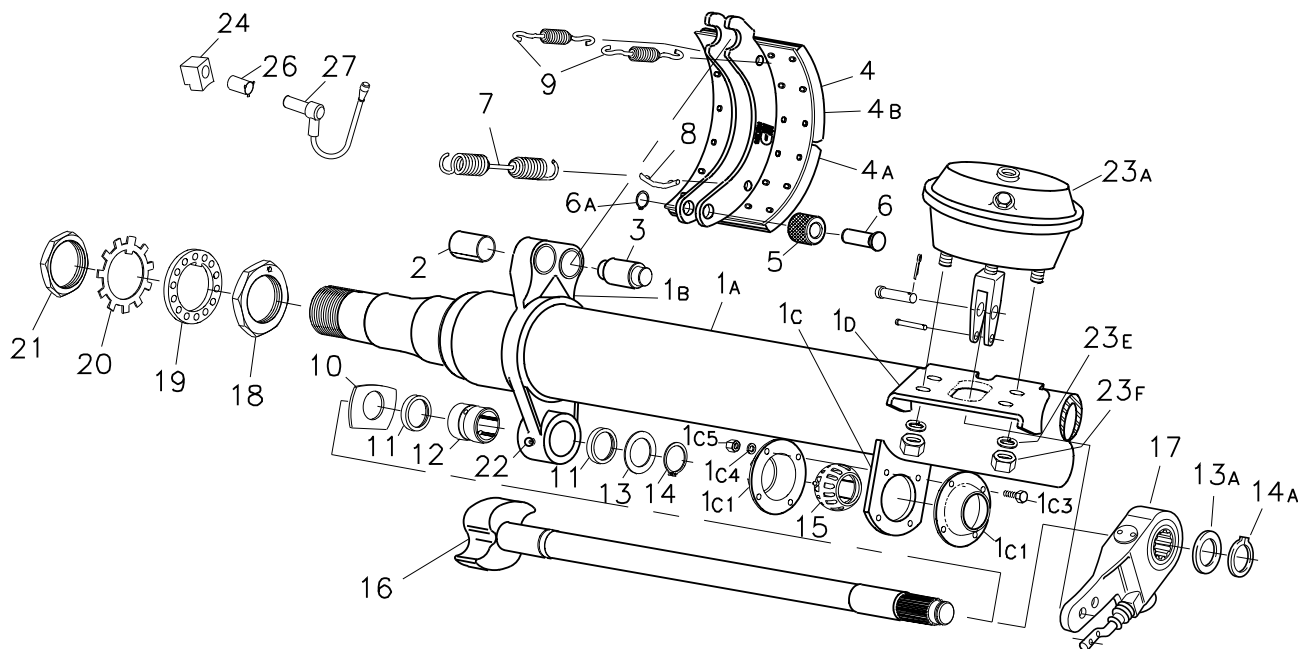

## Brake Shoe Hardware Kit

**K71-460-00**

Fits "PQ" style Dexter 10-27K 12 1/4" air brake axles. For one brake.

DX Part No.	Quantity	Part Description
005-076-00	2	Washer
014-057-00	2	Roller
014-068-00	2	Bushing
046-092-00	1	Retractor Spring
046-097-00	2	Shoe Keeper Spring
056-010-00	2	Roller Pin
056-017-00	2	Anchor Pin
056-018-00	2	Retainer Pin
069-018-00	2	Snap Ring for .750 Shaft
059-553-00	1	Instruction Sheet

## Brake Block Kit

**K71-133-00**

For one Dexter 12 1/4" x 7 1/2" brake.

DX Part No.	Quantity	Part Description
022-018-00	48	Rivet
041-057-01	2	Brake Block
041-060-01	2	Brake Block
059-191-00	1	Instruction sheet

ns - not shown

## Camshaft Repair Kit

**K71-101-00**

Fits "P" and "PQ" style Dexter 10K, 12K, 15K, and 12 1/4" x 7 1/2" air brake axles. For one brake.

DX Part No.	Quantity	Part Description
005-074-00	1	'D' Washer Camshaft
005-075-00	2	Camshaft Washer
005-134-00	1	Plain Washer
010-052-00	2	Seal
014-056-00	1	Camshaft Bushing
014-058-00	1	Camshaft Support Bushing
061-006-00	1	Grease Fitting
069-020-00	2	Camshaft Retainer
069-078-00	1	Snap Ring
059-663-00	1	Instruction Sheet

Axle beams are produced using the latest in friction welding technology.

**AXLE/BRAKE COMPONENTS**

# Axle/Brake Components



1 1/4" X 7 1/2" BRAKE SIZE

AXLE/BRAKE COMPONENTS

'PQ' Style

Item	Part No.	Qty per Axle	Description	Comments
1A	D-2L12	1	Beam Options	Light Wall 22,500# Rating
	D-2M12	1	Beam Options	Medium Wall 25,000# Rating; with Air Ride 22,500#
	D-2H12	1	Beam Options	Heavy Wall, 27,500# Rating; with Air Ride 25,000#
1B*	036-114-02	2	Spider (using anchor pin bushing)	Weld on (includes #2)
1C	034-031-00	2	Bracket - Camshaft Support	Weld-on
1C1	034-032-00	4	Retainer Plate	
1C3	007-139-00	8	Bolt - Retainer Plate Attachment	
1C4	005-079-00	8	Lock Washer - Cover Attachment	
1C5	006-099-00	8	Nut - Retainer Plate Attachment	
1D	034-048-00	2	Bracket - Air chamber Mounting	Weld-on Standard
2	014-068-00	4	Bushing - Spider Anchor Pin	
3	056-017-00	4	Anchor Pin	
4	040-320-01	4	Shoe and Lining Assembly	Friction Code FF
4A	041-060-01	4	Lining - Brake Block Cam	(FMSI 4591 D)
4B	041-057-01	4	Lining - Brake Block Anchor	(FMSI 4591 D)
5	014-057-00	4	Roller	
6	056-010-00	4	Retainer - Roller Pin	
6A	069-018-00	4	Retainer Ring	
7	046-092-00	2	Spring - Shoe Retractor	Blue color
8	056-018-00	4	Retainer Pin - Retractor Spring	
9	046-097-00	4	Spring - Shoe Keeper	Orange Color
10	005-074-00	2	'D' Washer - Camshaft	.06 thick
11	010-052-00	4	Grease Seal	
12	014-056-00	2	Bushing - Camshaft Spider	Nylon
13	005-075-00	1	Washer	
13A	005-134-00	2	Washer - Camshaft Slack Adjuster End	For 28-spline Camshafts only
14	069-020-00	2	Snap Ring	
14A	069-078-00	2	Retainer - Camshaft Slack Adjuster End	For 28-spline Camshafts only
15	014-058-00	2	Bushing - Camshaft Support	Nylon
16	034-xxx-xx	2	Camshaft LH/RH	See Camshaft section for options
ns	055-039-00	2	Slack Adjuster - Manual	1.46 x 28-spline
17	055-040-99	2	Slack Adjuster Angled Automatic 1.46 x 28-spline 6" arm	Boxed kit includes clevis, pins, gage, and instructions
18	006-114-00	2	Nut - Inner Spindle Bearing	
19	005-098-00	2	Lock Washer - Indexing	
20	005-099-00	2	Lock Washer - Tab	
21	006-115-00	2	Nut - Outer Spindle	
22	061-006-00	2	Grease Fitting 65°	
23A	034-xxx-xx	2	Air Chamber Assembly (includes item 23E, 23F)	See Air Chamber section for options
ns	055-057-00	2	Clevis for manual slacks only	Clevis, Clevis Pin & Cotter Pin for Manual Slacks
23E		4	Lock Washer - Air chamber Mounting (included in item 23A)	
23F		4	Nut - Air Chamber Mounting (included in item 23A)	
24	024-100-00	2	Sensor block	
26	097-002-00	2	Retainer Clip	
27	097-003-00	2	ABS Sensor, 90°	Haldex
	097-007-00	2	ABS Sensor, 90°	Meritor - Wabco

\* Not for individual resale

xx - See Camshaft section for part number that varies by length



# Axle/Brake Components

'Q' Style

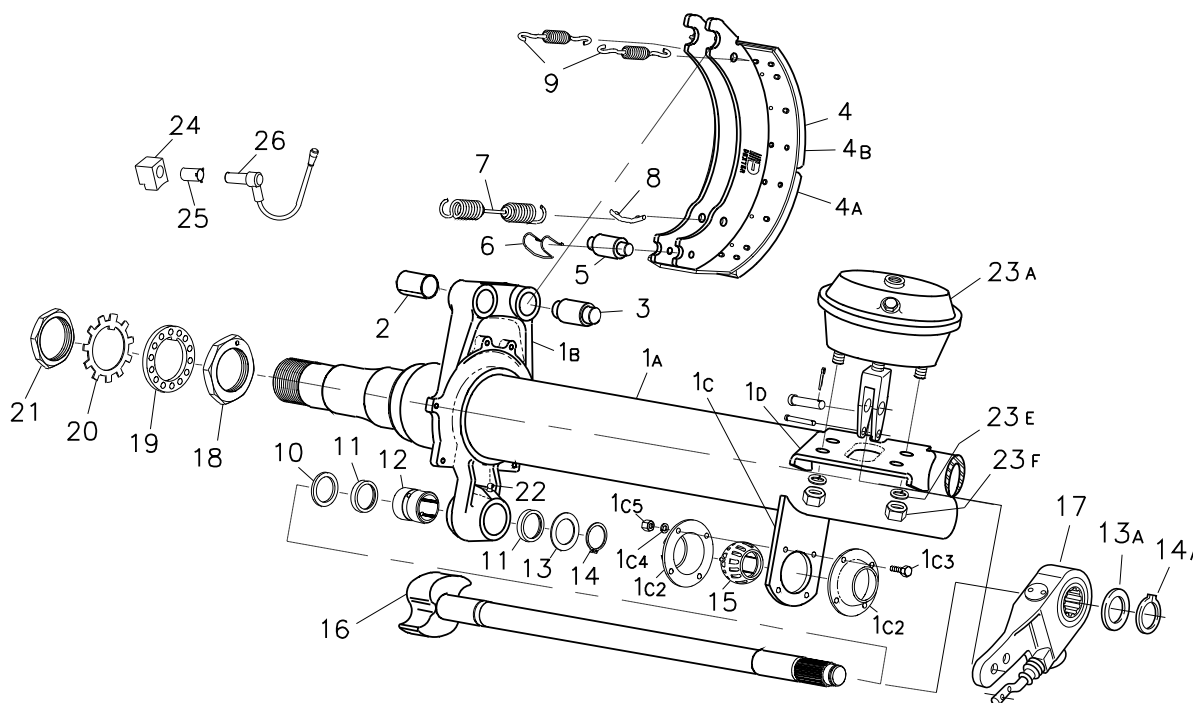

**16 1/2" X 7" BRAKE SIZE**

**AXLE/BRAKE COMPONENTS**

## Brake Shoe Hardware Kit K71-136-00

Fits "Q" quick change Dexter 16 1/2" x 7" air brake axles. For one brake.

DX Part No.	Quantity	Part Description
014-065-00	2	Roller
014-068-00	2	Spider Bushing
046-096-00	1	Retractor Spring 16 1/2" Brake-Orange
046-097-00	2	Keeper Spring
056-017-00	2	Anchor Pin
056-018-00	2	Spring Retainer
071-122-00	2	Roller Retainer
059-554-00	1	Instruction Sheet

## Brake Block Kit K71-138-00

For one Dexter 16 1/2" x 7" air brake.

DX Part No.	Quantity	Part Description
022-018-00	48	Rivet
041-058-01	2	Brake Block
041-059-01	2	Brake Block
059-191-00	1	Instruction sheet

ns - not shown

## Camshaft Repair Kit K71-135-00

Fits all "Q" quick change Dexter 16 1/2" x 7" air brake axles. For one brake.

DX Part No.	Quantity	Part Description
005-096-00	1	Camshaft Washer
005-097-00	2	Camshaft Washer
005-134-00	1	Plain Washer
010-052-00	2	Seal
014-056-00	1	Camshaft Bushing
014-058-00	1	Camshaft Support Bushing
061-006-00	1	Grease Fitting
069-020-00	2	Camshaft Retainer
069-078-00	1	Snap Ring
059-554-00	1	Instruction Sheet

Axle beams are produced using the latest in friction welding technology.

# Axle/Brake Components



16 1/2" X 7" BRAKE SIZE

AXLE/BRAKE COMPONENTS

'Q' Style

Item	Part No.	Qty per Axle	Description	Comments
1A	D-2L16	1	Beam Options	Light Wall 22,500# Rating
	D-2M16	1	Beam Options	Medium Wall 25,000# Rating; with Air Ride 22,500#
	D-2H16	1	Beam Options	Heavy Wall, 27,500# Rating; with Air Ride 25,000#
1B*	036-092-02	2	Spider	Weld on (includes #2)
1C	034-047-04	2	Bracket - Camshaft Support	Weld-on
1C2	034-032-00	4	Retainer Plate	
1C3	007-139-00	8	Bolt - Retainer Plate Attachment	
1C4	005-079-00	8	Lock Washer - Cover Attachment	
1C5	006-099-00	8	Nut - Retainer Plate Attachment	
1D	034-048-00	2	Bracket - Air chamber Mounting	Weld-on Standard
2	014-068-00	4	Bushing - Spider Anchor Pin	
3	056-017-00	4	Anchor Pin	
4	040-180-00	4	Shoe and Lining Assembly	Friction Code FF
4A	041-058-01	4	Lining - Brake Block Cam	(FMSI 4515 D)
4B	041-059-01	4	Lining - Brake Block Anchor	(FMSI 4515 D)
5	014-065-00	4	Roller	
6	071-122-00	4	Retainer - Roller	
7	046-096-00	2	Spring - Shoe Retractor	Orange Color
8	056-018-00	4	Retainer Pin - Retractor Spring	
9	046-097-00	4	Spring - Shoe Keeper	Orange Color
10	005-096-00	2	Washer - Camshaft	.120 thick
11	010-052-00	4	Grease Seal	
12	014-056-00	2	Bushing - Camshaft Spider	Nylon
13	005-097-00	2	Washer	
13A	005-134-00	2	Washer - Camshaft Slack Adjuster End	For 28-spline Camshafts only
14	069-020-00	2	Snap Ring	
14A	069-078-00	2	Retainer - Camshaft Slack Adjuster End	For 28-spline Camshafts only
15	014-058-00	2	Bushing - Camshaft Support	Nylon
16	034-xxx-xx	2	Camshaft LH/RH	See Camshaft section for options
ns	055-039-00	2	Slack Adjuster - Manual	1.46 x 28-spline
17	055-040-98	2	Slack Adjuster Straight Automatic 1.46 x 28-spline 6" arm	Boxed kit includes clevis, pins, gage, and instructions
18	006-114-00	2	Nut - Inner Spindle Bearing	
19	005-098-00	2	Lock Washer - Indexing	
20	005-099-00	2	Lock Washer - Tab	
21	006-115-00	2	Nut - Outer Spindle	
22	061-006-00	2	Grease Fitting 65°	
23A	034-xxx-xx	2	Air chamber Assembly (includes item 23E, 23F)	See Air Chamber section for options
ns	055-057-00	2	Clevis for manual slacks only	Clevis, Clevis Pin & Cotter Pin for Manual Slacks
23E		4	Lock Washer - Air chamber Mounting (included in item 23A)	
23F		4	Nut - Air Chamber Mounting (included in item 23A)	
24	024-100-00	2	Sensor block	
25	097-002-00	2	Retainer Clip	
26	097-003-00	2	ABS Sensor, 90°	Haldex
	097-007-00	2	ABS Sensor, 90°	Meritor - Wabco

\* Not for individual resale

xx - See Camshaft section for part number that varies by length

# Tandem Air System



Two Reservoir – Two Valve System

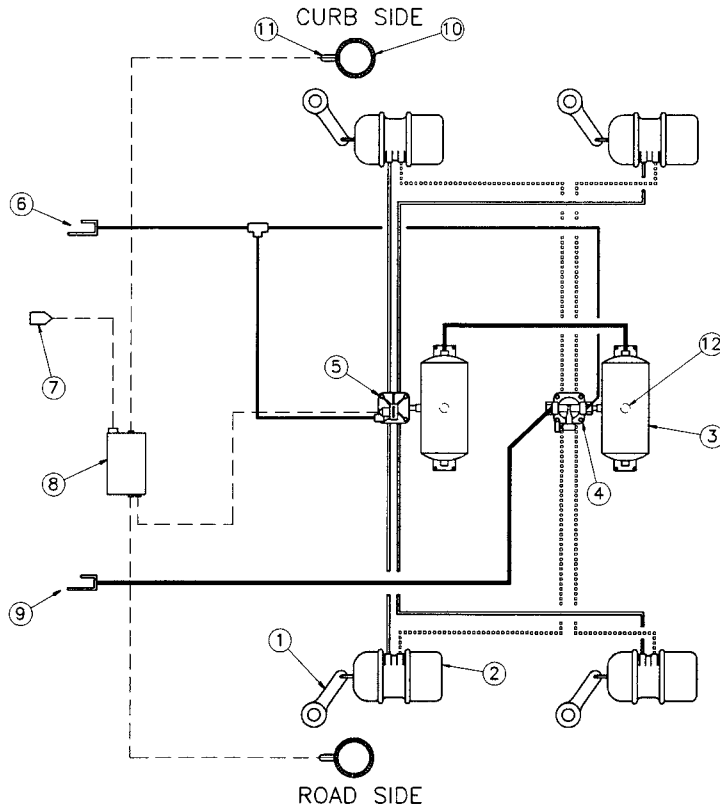

NOTE: ITEMS 10 AND 11 SHOULD BE PLACED ON THE AXLES WITH THE GREATEST LIKELIHOOD OF WHEEL LOCK.

——— SUPPLY----- (1/2 OD)  
 ——— CONTROL----- (3/8 OD)  
 ——— DELIVERY----- (1/2 ID)  
 ..... PARK----- (1/2 ID)  
 - - - - - WIRING HARNESS

AIR BRAKE COMPONENTS AND SYSTEM SCHEMATIC ARE DESIGNED TO ALLOW COMPLIANCE WITH FMVSS 121 DOCKET 90-3.

THIS SCHEMATIC IS FOR INFORMATIONAL PURPOSES ONLY. IT IS THE VEHICLE MANUFACTURERS ULTIMATE RESPONSIBILITY TO CERTIFY THEIR SYSTEM MEETS ALL APPLICABLE REGULATIONS.

PIPE NIPPLES USED TO MOUNT BRAKE VALVES MUST BE HEAVY WALL TYPE PER SAE J514.

ITEM	DESCRIPTION	QTY.
1	SLACK ADJUSTER	4
2	SPRING BRAKE	4
3	RESERVOIR	2
4	RT4 VALVE 70 PSI	1
5	ABS VALVE	1
6	GLADHAND SERVICE/CONTROL	1
7	7-WAY CONNECTOR	1
8	ECU	1
9	GLADHAND EMERGENCY/SUPPLY	1
10	EXCITER RING	2
11	SENSOR	2
12	DRAIN COCK	2

TANDEM AXLE INSTALLATION SYSTEM FOR HALDEX MODEL 2S / 1M

TANDEM AIR SYSTEM

**Note:** This schematic is for reference only. If your system is configured differently or you have a different supplier's part numbers, consult with the authorized supplier for proper use, location and installation of your components.



## Small S Head Hi-Rise

### 28 Spline

Part Number		A	B	C
LH	RH			
034-188-00	034-189-00	21.125	2.219	For 1.50 diameter shaft*
034-188-01	034-189-01	16.375	2.219	For 1.50 diameter shaft*
034-188-03	034-189-03	22.312	2.219	For 1.50 diameter shaft*
034-188-04	034-189-04	20.312	2.219	For 1.50 diameter shaft
034-188-05	034-189-05	23.375	2.219	For 1.50 diameter shaft
034-188-06	034-189-06	30.000	2.219	For 1.50 diameter shaft
034-188-07	034-189-07	29.000	2.219	For 1.50 diameter shaft
034-188-08	034-189-08	19.500	2.219	For 1.50 diameter shaft
034-188-09	034-189-09	26.500	2.219	For 1.50 diameter shaft
034-188-10	034-189-10	7.437	2.219	For 1.50 diameter shaft
034-188-11	034-189-11	24.625	2.219	For 1.50 diameter shaft

\* No extra charge for these lengths

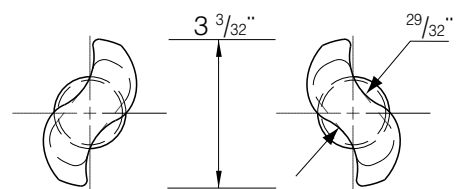

Right Hand

Left Hand

Viewed from head end

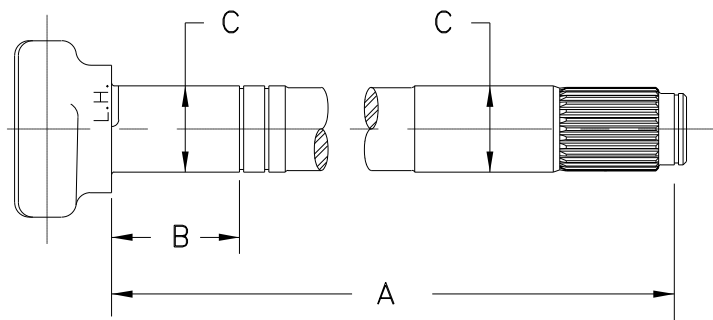



# S Head Camshafts



## Large S Head Hi-Rise

### 28 Spline

Part Number		A	B	C
LH	RH			
034-192-00	034-193-00	16.625	2.219	For 1.50 diameter shaft*
034-192-01	034-193-01	20.375	2.219	For 1.50 diameter shaft
034-192-02	034-193-02	30.000	2.219	For 1.50 diameter shaft
034-192-03	034-193-03	23.438	2.219	For 1.50 diameter shaft*
034-192-04	034-193-04	26.500	2.219	For 1.50 diameter shaft
034-192-05	034-193-05	22.625	2.219	For 1.50 diameter shaft
034-192-06	034-193-06	19.500	2.219	For 1.50 diameter shaft
034-192-07	034-193-07	29.000	2.219	For 1.50 diameter shaft
034-192-08	034-193-08	25.000	2.219	For 1.50 diameter shaft
034-192-09	034-193-09	28.000	2.219	For 1.50 diameter shaft
034-192-10	034-193-10	24.375	2.219	For 1.50 diameter shaft
034-192-11	034-193-11	7.438	2.219	For 1.50 diameter shaft

\* No extra charge for these lengths

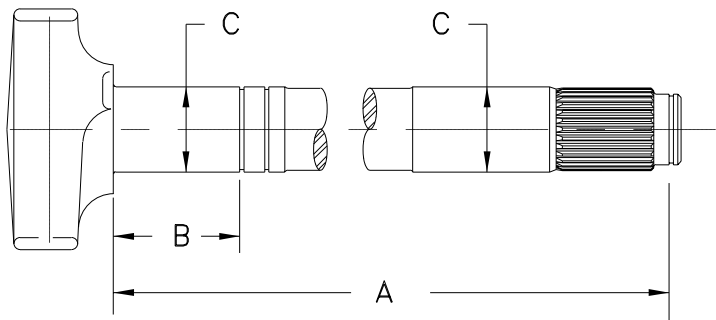
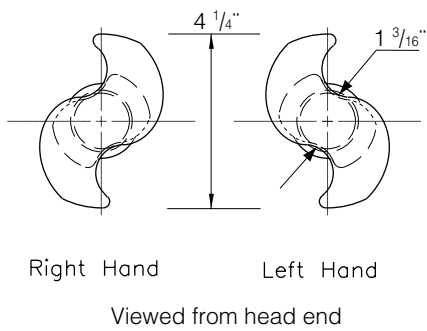

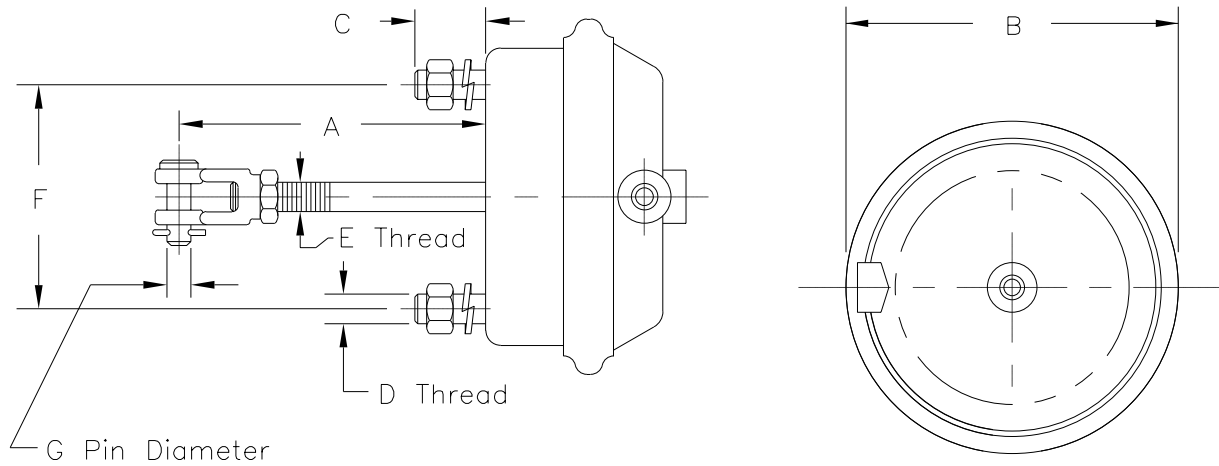

Part Number	Size	A	B	C	D	E	F	G	Recommended Application
034-260-07	Type 20	5.62	7.00	1.25	5/8-11	5/8-18	4.75	.50	12 1/4" Brake with Tramec Angled Automatic Slack
034-260-08	Type 20	6.38	7.00	1.25	5/8-11	5/8-18	4.75	.50	12 1/4" Brake with Straight Manual Slack
034-059-01	Type 24	7.00	7.50	1.25	5/8-11	5/8-18	4.75	.50	Optional 16 1/2" Brake with Tramec Angled Automatic Slack
034-059-07	Type 24	5.62	7.50	1.25	5/8-11	5/8-18	4.75	.50	12 1/4" Brake with Tramec Angled Automatic Slack
034-059-08	Type 24	6.38	7.50	1.25	5/8-11	5/8-18	4.75	.50	12 1/4" Brake with Straight Manual Slack
034-057-01	Type 30	7.00	8.50	1.25	5/8-11	5/8-18	4.75	.50	Standard 16 1/2" Brake
034-057-07	Type 30	5.62	8.50	1.25	5/8-11	5/8-18	4.75	.50	12 1/4" Brake with Tramec Angled Automatic Slack
034-057-08	Type 30	6.38	8.50	1.25	5/8-11	5/8-18	4.75	.50	12 1/4" Brake with Straight Manual Slack

**Note:** Clevis assembly NOT included with air chamber. See brake section for Clevis kits.

# Spring Brake Air Chambers

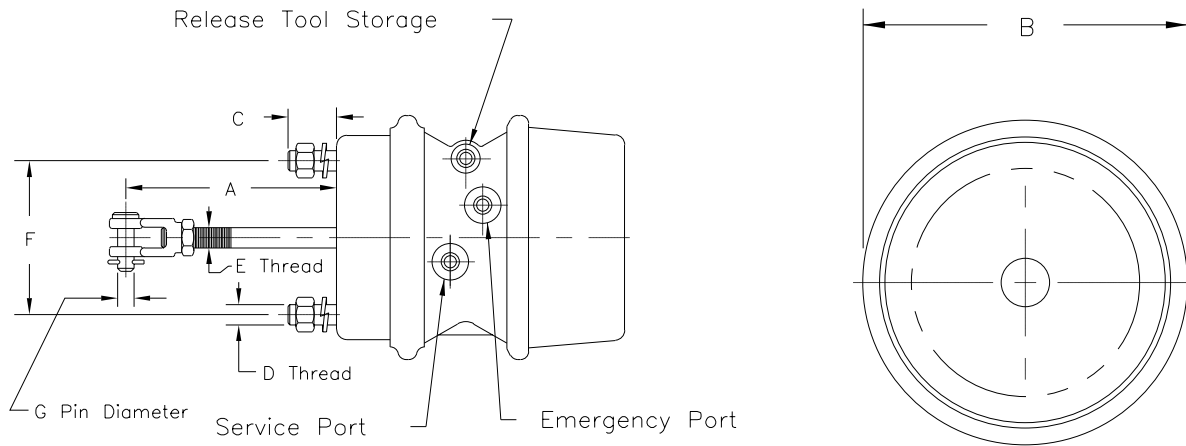

Part Number	Size	A	B	C	D	E	F	G	Recommended Application
034-261-07	Type 20-24	5.62	7.53	1.25	$\frac{5}{8}$ -11	$\frac{5}{8}$ -18	4.75	.50	12 $\frac{1}{4}$ " Brake with Tramec Angled Automatic Slack
034-261-08	Type 20-24	6.38	7.53	1.25	$\frac{5}{8}$ -11	$\frac{5}{8}$ -18	4.75	.50	12 $\frac{1}{4}$ " Brake with Straight Manual Slack
034-060-01	Type 24-30	7.00	7.50	1.25	$\frac{5}{8}$ -11	$\frac{5}{8}$ -18	4.75	.50	Optional 16 $\frac{1}{2}$ " Brake with Tramec Angled Automatic Slack
034-060-07	Type 24-30	5.62	7.50	1.25	$\frac{5}{8}$ -11	$\frac{5}{8}$ -18	4.75	.50	12 $\frac{1}{4}$ " Brake with Tramec Angled Automatic Slack
034-060-08	Type 24-30	6.38	7.50	1.25	$\frac{5}{8}$ -11	$\frac{5}{8}$ -18	4.75	.50	12 $\frac{1}{4}$ " Brake with Straight Manual Slack
034-058-01	Type 30-30	7.00	8.50	1.25	$\frac{5}{8}$ -11	$\frac{5}{8}$ -18	4.75	.50	Standard 16 $\frac{1}{2}$ " Brake
034-058-07	Type 30-30	5.62	8.50	1.25	$\frac{5}{8}$ -11	$\frac{5}{8}$ -18	4.75	.50	12 $\frac{1}{4}$ " Brake with Tramec Angled Automatic Slack
034-058-08	Type 30-30	6.38	8.50	1.25	$\frac{5}{8}$ -11	$\frac{5}{8}$ -18	4.75	.50	12 $\frac{1}{4}$ " Brake with Straight Manual Slack

**Note:** Clevis assembly NOT included with air chamber. See brake section for Clevis kits.

# Tandem Axle Configurations



Off-Road Applications

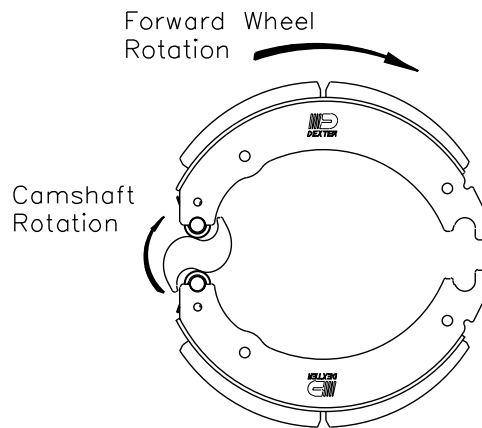
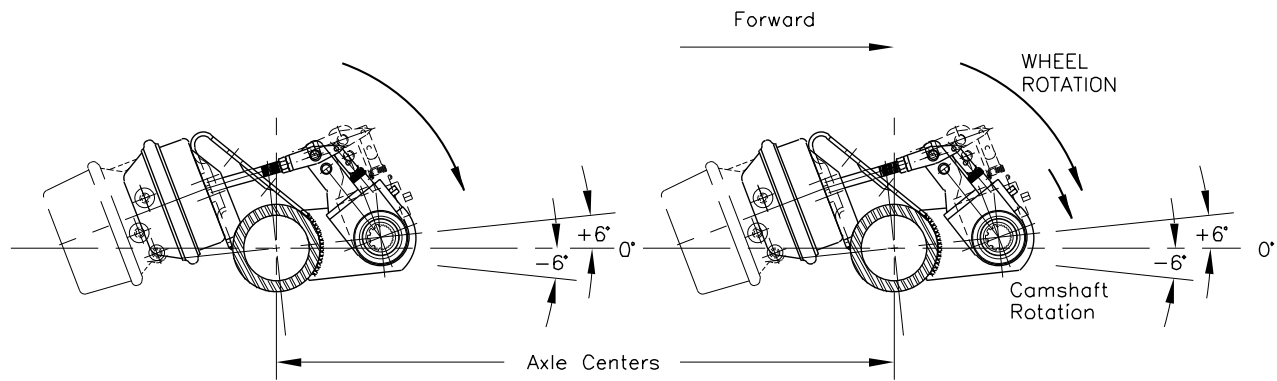

**Note:**

1. Position of air chambers as shown results in optimum clearances.
2. Use of equal length service lines is recommended.
3. To assure welds are within approved neutral axis zone quadrants, maximum rotation of camshaft position is  $+6^\circ$  up to  $-6^\circ$  down from  $0^\circ$  neutral axis.

**AIR CHAMBERS**

# Tandem Axle Configurations



Over-the-Highway Applications

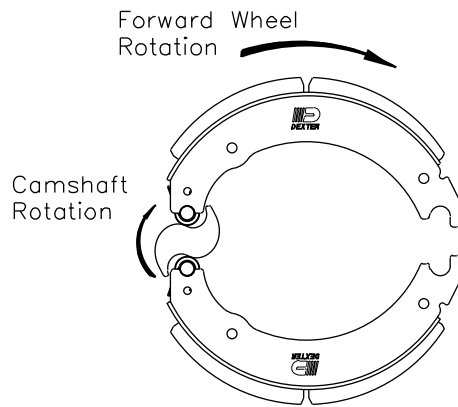
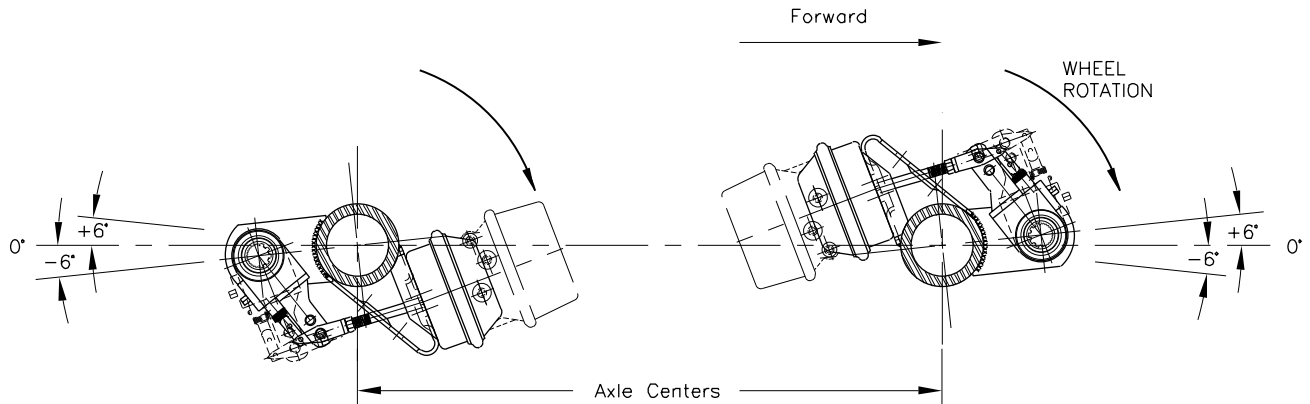

**Note:**

1. Position of air chambers as shown results in optimum clearances.
2. Use of equal length service lines is recommended.
3. To assure welds are within approved neutral axis zone quadrants, maximum rotation of camshaft position is  $+6^\circ$  up to  $-6^\circ$  down from  $0^\circ$  neutral axis.



## Suspension Kits

Order appropriate number of HAP kits and springs for a complete suspension kit

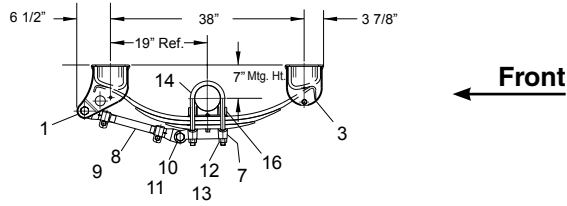

	H-9700 Underslung		Dexter Spring
	HAP-101-00	HAP-201-00	072-048-00
Qty for Single	1	n/a	2
Qty for Tandem	1	1	4
Qty for Triple	1	2	6

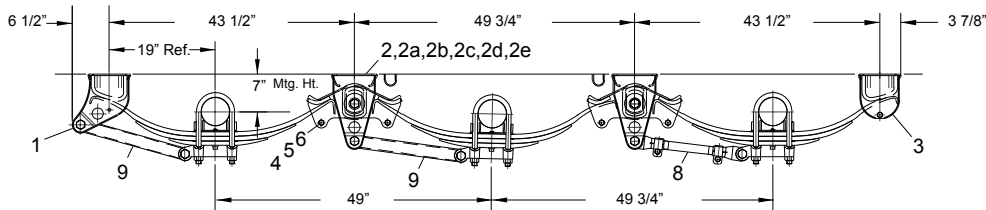
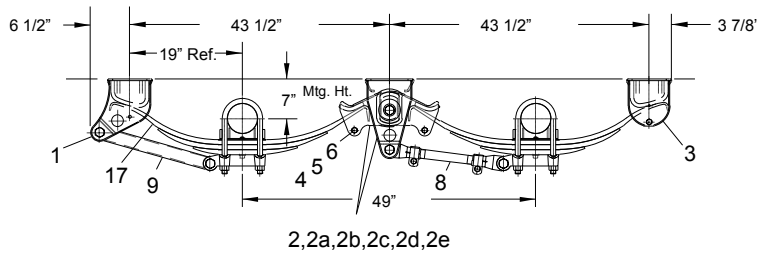

Item	Description	HAP-101-00	HAP-201-00	Comments
1	Front Hanger	2	n/a	
2	Hanger & Equalizer Assembly	n/a	2	
2a	Hanger	n/a	2	
2b	Equalizer Assembly w/rubber bushing	n/a	2	
2c	Hex Cap Screw	n/a	2	1 1/8"-7 UNC x 6 5/8" GR5
2d	Washer	n/a	4	1/8" x 1 1/4" ID x 2 1/4" OD
2e	Hex Locknut	n/a	2	1 1/8"-7 UNC GR5
3	Rear Hanger	2	n/a	Complete w/bolt spacer & nut
4	Sleeve Spacer	n/a	4	
5	Hex Nut 5/8"	n/a	4	
6	Hex Bolt 5/8"	n/a	4	
7	Bottom Plate	2	2	
8	Torque Arm - Adjustable	1	1	
9	Torque Arm - Non-Adjustable	1	1	
10	Torque Arm Bolt	4	4	
11	Locknut Flanged	4	4	
12	Washer 7/8" Flat	8	8	
13	Hex Nut 7/8"	8	8	
14	U-Bolt 1 1/4" Length	4	4	
15	Spring 3-Leaf Standard	2	2	Dexter part number 072-048-00 sold separately
16	Spring Seat 3/4" High	2	2	
ns	Galvanized Liner	2	2	

**Note:** Mounting height shown above is in the unloaded condition.

# H-9700 Overslung

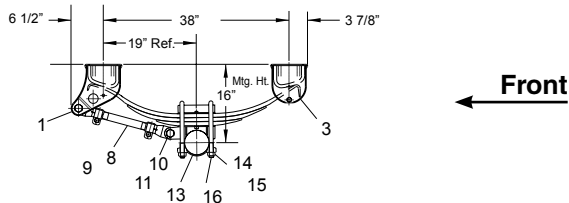

## Suspension Kits

Order appropriate number of HAP kits and springs for a complete suspension kit

	H-9700 Overslung		Dexter Spring
	HAP-102-00	HAP-202-00	072-048-00
Qty for Single	1	n/a	2
Qty for Tandem	1	1	4
Qty for Triple	1	2	6

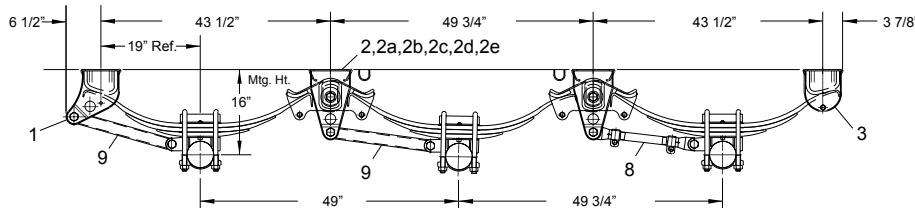
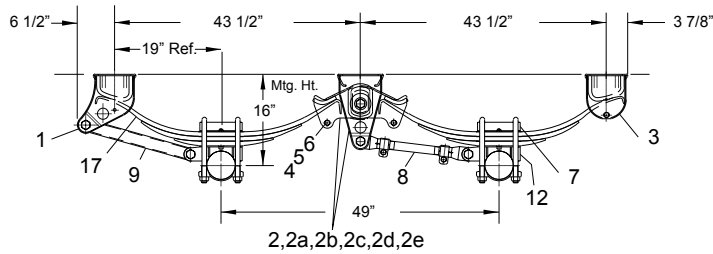

Item	Description	HAP-102-00	HAP-202-00	Comments
1	Front Hanger	2	n/a	
2	Hanger & Equalizer Assembly	n/a	2	
2a	Hanger	n/a	2	
2b	Equalizer Assembly w/rubber bushing	n/a	2	
2c	Hex Cap Screw	n/a	2	1 1/8"-7 UNC x 6 5/8" GR5
2d	Washer	n/a	4	1/8" x 1 1/4" ID x 2 1/4" OD
2e	Hex Locknut	n/a	2	1 1/8"-7 UNC GR5
3	Rear Hanger	2	n/a	Complete w/bolt spacer & nut
4	Sleeve Spacer	n/a	4	
5	Hex Nut 5/8"	n/a	4	
6	Hex Bolt 5/8"	n/a	4	
7	Top Plate	2	2	
8	Torque Arm - Adjustable	1	1	
9	Torque Arm - Non-Adjustable	1	1	
10	Torque Arm Bolt	4	4	
11	Locknut Flanged	4	4	
12	Spring Seat 3/4" High	2	2	
13	Bottom Plate 5" Round	2	2	
14	Washer 7/8" Flat	8	8	
15	Hex Nut 7/8"	8	8	
16	U-Bolt 10 3/4" Length	4	4	
17	Spring 3-Leaf Standard	2	2	Dexter part number 072-048-00 sold separately
ns	Galvanized Liner	2	2	

**Note:** Mounting height shown above is in the unloaded condition.



## WHAT PRODUCTS ARE COVERED

All Dexter Axle Company ("Dexter Axle") trailer axles, suspensions, and brake control systems excluding Dexter 6000 series Manufactured Housing Axles.

## LIMITED 2 YEAR WARRANTY

Dexter Axle warrants to the original purchaser that its axles, suspension systems, and E/H hydraulic brake actuators shall be free from defects in material and workmanship for a period of two (2) years from the date of first sale of the trailer incorporating such components.

## LIMITED 5 YEAR WARRANTY

Dexter Axle warrants to the original purchaser that its Nev-R-Lube® bearings and the suspension components only, of its Torflex® Axles shall be free from defects in material and workmanship for a period of five (5) years from the date of first sale of the trailer incorporating such components.

## LIMITED 7 YEAR WARRANTY

Dexter Axle warrants to the original purchaser that its Predator Series® electric brake controllers shall be free from defects in material and workmanship for a period of seven (7) years from the date of purchase.

## EXCLUSIVE REMEDY

Dexter Axle will, at its option, repair or replace the affected components of any defective axle, repair or replace the entire defective axle, or refund the then-current list price of the axle. In all cases, a reasonable time period must be allowed for warranty repairs to be completed. Allowance will only be made for installation costs specifically approved by Dexter Axle.

## WHAT YOU MUST DO

In order to make a claim under these warranties:

1. You must be the original purchaser of the vehicle in which the spring suspension axles or Torflex® axles were originally installed.
2. You must promptly notify us within the warranty period of any defect, and provide us with the axle serial number and any substantiation which may include, but is not limited to, the return of part(s) that we may reasonably request.
3. The axles or suspensions must have been installed and maintained in accordance with good industry practice and any specific Dexter Axle recommendations, including those specified in Dexter Axle's publication "Operation Maintenance Service Manual."

## EXCLUSIONS

These warranties do not extend to or do not cover defects caused by:

1. The connecting of brake wiring to the trailer wiring or trailer wiring to the towing vehicle wiring.
2. The attachment of the running gear to the frame.
3. Hub imbalance, or any damage caused thereby.
4. Parts not supplied by Dexter Axle.

5. Any damage whatever caused by or related to any alteration of the axle including welding supplemental brackets to the axle.
6. Use of an axle on a unit other than the unit to which it was originally mounted.
7. Normal wear and tear.
8. Alignment.
9. Improper installation.
10. Unreasonable use (including failure to provide reasonable and necessary maintenance as specified in Dexter Axle's publication "Operation Maintenance Service Manual" including required maintenance after "Prolonged Storage").
11. Improper wheel nut torque.
12. Cosmetic finish or corrosion.

## LIMITATIONS

1. **In all cases, Dexter Axle reserves the right to fully satisfy its obligations under the Limited Warranties by refunding the then-current list price of the defective axle (or, if the axle has been discontinued, of the most nearly comparable current product).**
2. Dexter Axle reserves the right to furnish a substitute or replacement component or product in the event an axle or any component of the axle is discontinued or is otherwise unavailable.
3. These warranties are nontransferable.

## GENERAL

**THE FOREGOING WARRANTIES ARE EXCLUSIVE AND IN LIEU OF ALL OTHER WARRANTIES EXCEPT THAT OF TITLE, WHETHER WRITTEN, ORAL OR IMPLIED, IN FACT OR IN LAW (INCLUDING ANY WARRANTY OF MERCHANTABILITY OR FITNESS FOR A PARTICULAR PURPOSE).**

These warranties give you specific legal rights, and you may also have other rights which vary from state to state.

**DEXTER AXLE HEREBY EXCLUDES INCIDENTAL AND CONSEQUENTIAL DAMAGES, INCLUDING LOSS OF TIME, INCONVENIENCE, LOSS OF USE, TOWING FEES, TELEPHONE CALLS OR COST OF MEALS, FOR ANY BREACH OF ANY EXPRESS OR IMPLIED WARRANTY.**

Some states do not allow limitations on how long an implied warranty lasts, or the exclusion or limitation of incidental or consequential damages, so the above exclusion or limitation may not apply to you.

Inquiries regarding these warranties should be sent to:

Dexter Axle Company  
P.O. Box 250  
Elkhart, Indiana 46515





**Genuine Dexter axles and components are available nationwide from our plant locations listed below or through our network of distributors. Check our web site for the distributor nearest you.**

**Visit us online at [www.dexteraxle.com](http://www.dexteraxle.com)**

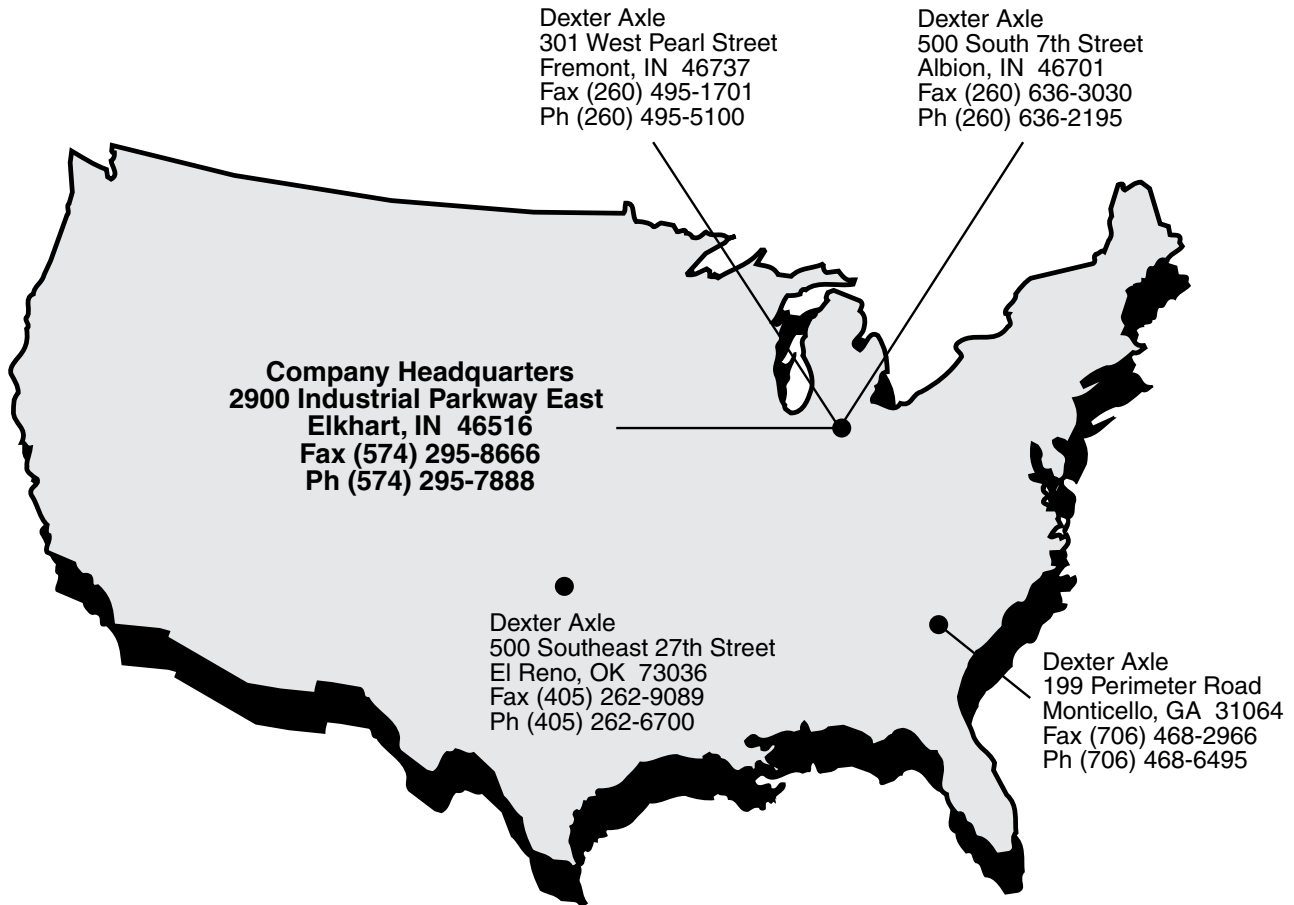

---

**NO PART OF THIS CATALOG MAY BE REPRODUCED WITHOUT DEXTER AXLE'S PERMISSION.  
ALL PART NUMBERS, DIMENSIONS AND SPECIFICATIONS IN THIS CATALOG ARE SUBJECT  
TO CHANGE WITHOUT NOTICE.**

---

**GEARED FOR INNOVATION SINCE 1960**



**DEXTER AXLE**

**[www.dexteraxle.com](http://www.dexteraxle.com)**

2900 Industrial Parkway East ■ Elkhart, IN 46516  
Phone: 574-295-7888 ■ Fax: 574-295-8666