

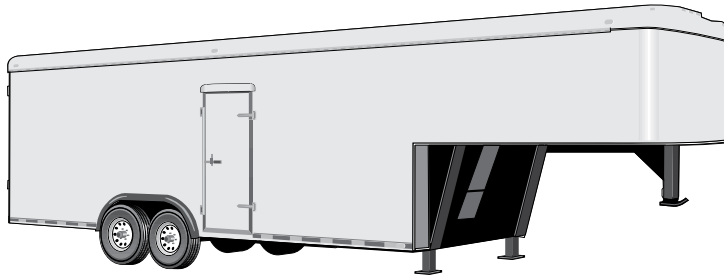

# General Applications

7200 LBS. CAPACITY



## Axle Types

### 7200 Lbs. Capacity

- Complete service manual
- Precision machined steel spindles and integral cast iron hub/drums
- Finned brake drums for better heat dissipation
- Press-in wheel studs, 9/16" or 5/8"
- Improved bearing package; unitized seals
- Standard grease lubrication; optional oil bath; E-Z Lube® option
- 12 1/4" x 2 1/2" electric brakes, CSA approved at 7100 lbs.
- Inner wiring system for easier installation and protection of brake wiring



### D72 LEAF SPRING



- Heavy wall 3" diameter tube
- Straight or Drop spindles (4" drop only)
- High quality alloy steel springs in a variety of capacities
- Single, tandem, or triple axle assemblies with equalized suspensions
- Slipper leaf spring suspension
- Heavy duty suspension parts available
- Optional rubber bushed suspension
- Optional hanger and attaching parts kits available
- Durable, wear-resistant components
- 2 year limited warranty

- Totally rubber-cushioned for smooth, quiet, independent ride
- Easy installation with less maintenance
- Less transfer of road shock which insulates cargo from road shocks and vibration
- Rubber cords compounded for maximum dependability and durability
- Load-carrying cross member
- Self-damping action
- Independent wheel suspension system
- 5 year limited warranty on suspension system
- Low profile for maximum road clearance
- Various starting angles to control trailer height
- High and low profile brackets with optional mounting brackets are available
- Rubber cushioning eliminates metal-to-metal contact
- Shock absorption provided by the natural hysteresis of rubber
- Single or tandem axle assemblies
- Durable, wear-resistant components

**CAUTION:** Triple axle assemblies are NOT recommended for Torflex® axles.



## Articulation Dimensions

Dimensions are for top mount only. Side mount is .31" higher. Allow 3" bump clearance from full load.

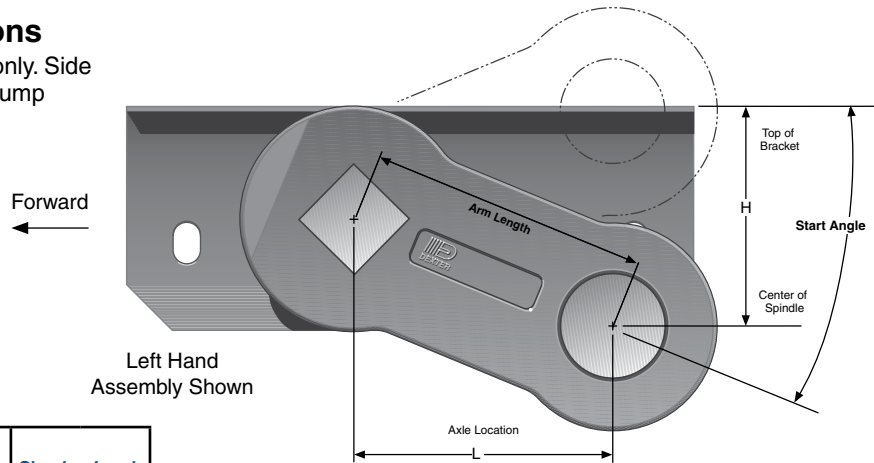

Left Hand Assembly Shown

Start Angle	Bracket Profile	No Load		Full Load		Shock Load	
		H	L	H	L	H	L
45° Down	Low	6.24	4.24	4.30	5.54	3.30	5.86
	High	6.99	4.24	5.05	5.54	4.05	5.86
22.5° Down	Low	4.30	5.54	2.00	6.00	0.96	5.91
	High	5.05	5.54	2.75	6.00	1.71	5.91
10° Down	Low	3.04	5.91	0.70	5.86	-0.30	5.54
	High	3.79	5.91	1.45	5.86	0.45	5.54
0°	Low	2.00	6.00	-0.30	5.54	-1.22	5.06
	High	2.75	6.00	0.45	5.54	-0.47	5.06
10° Up	Low	0.96	5.91	-1.22	5.06	-2.05	4.42
	High	1.71	5.91	-0.47	5.06	-1.30	4.42
22.5° Up	Low	-0.30	5.54	-2.24	4.24	-2.91	3.44
	High	0.45	5.54	-1.49	4.24	-2.16	3.44

### #12V Overhang Per Side

Spindle	Min.	Max.
Standard	7.00"	14.77"

**Note:** Positive numbers in the H column indicate the spindle is BELOW the top of the bracket. Conversely, negative numbers are ABOVE the top of the bracket.



## Full Load Dimensions

Dimensions are for low profile, top mount only. High profile brackets are .75" higher. Side mount is .31" higher. Allow 3" bump clearance from full load.

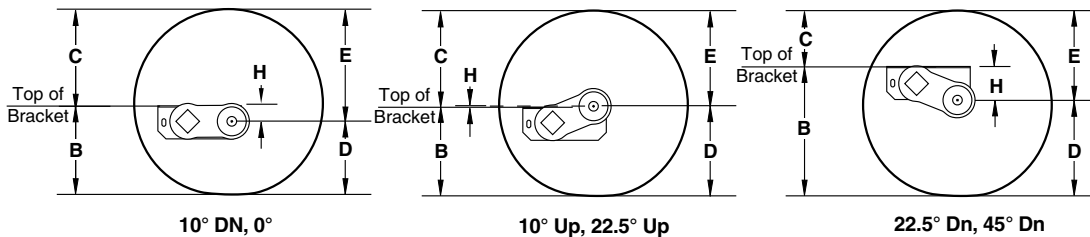

### Start Angle

Tire	* **		45° Down			22.5° Down			10° Down			0°			10° Up			22.5° Up		
	D	E	H	B	C	H	B	C	H	B	C	H	B	C	H	B	C	H	B	C
LT235/85R16	14.3	15.4	4.3	18.6	11.1	2.0	16.3	13.4	0.7	15.0	14.7	-0.3	14.0	15.7	-1.2	13.1	16.6	-2.2	12.1	17.6
7.50-16LT	14.9	16.7	4.3	19.2	12.4	2.0	16.9	14.7	0.7	15.6	16.0	-0.3	14.6	17.0	-1.2	13.7	17.9	-2.2	12.7	18.9
9.50-16.5LT	14.1	15.2	4.3	18.4	10.9	2.0	16.1	13.2	0.7	14.8	14.5	-0.3	13.8	15.5	-1.2	12.9	16.4	-2.2	11.9	17.4

Columns D and E are dimensional examples only:

\* D – Static Loaded Radius

\*\* E – Inflated Radius



**7200 LBS. CAPACITY**



## Bracket Dimensions

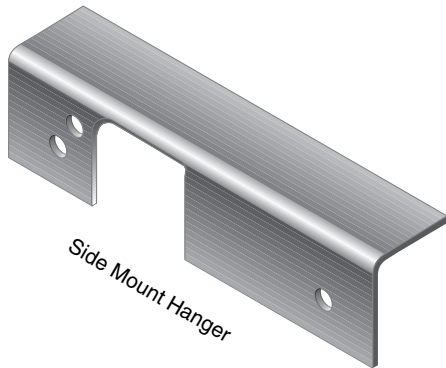
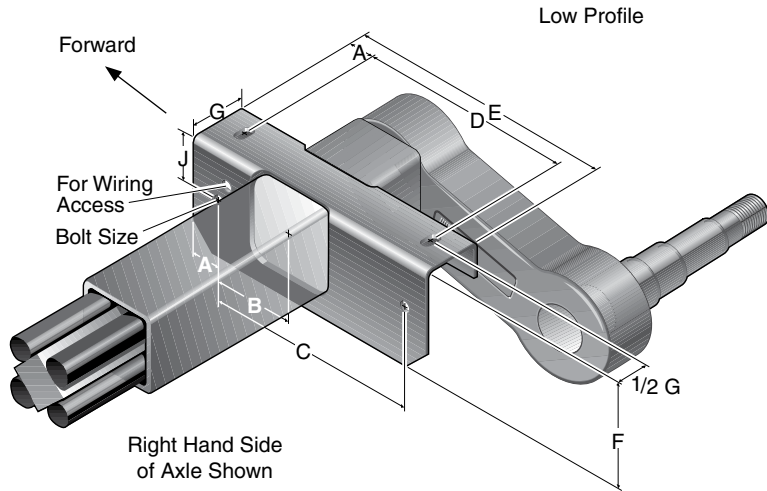

### #12V Bracket Dimensions

	Low	High
A	1.25	1.25
B	3.50	3.50
C	9.50	9.50
D	9.00	9.00
E	12.00	12.00
F	4.37	5.12
G	2.50	2.50
J	2.06	2.06
N	----	1.03
P	----	1.00
Q	----	1.00
Bolt Size	5/8" bolt	
Tube Size	3.50	3.50

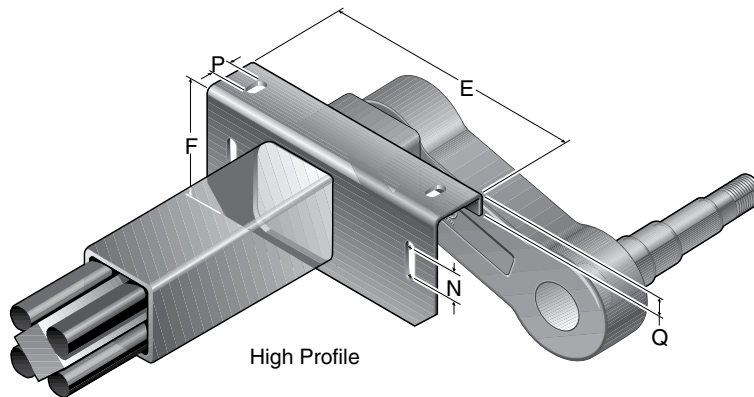

# Leaf Spring Application Information



**7200 LBS. CAPACITY**

## Slipper Spring Axle Assemblies

Hanger Kits			Quantity Per Kit		
Part No.	Description	Height	HGR-138-00	HGR-238-00	HGR-338-00
028-009-01	Front Hanger	5.00"	2	2	2
029-005-01	Center Hanger	4.50"	----	2	4
030-006-01	Rear Hanger	6.38"	2	2	2

Attaching Parts Kits		A/P-103-00	A/P-202-00 <sup>§</sup>	A/P-216-00 <sup>‡</sup>	A/P-302-00 <sup>§</sup>	A/P-316-00 <sup>‡</sup>
Part No.	Description					
006-007-01	5/16-18 Locknut	2	4	4	6	6
006-011-00	Keeper Nut	2	4	4	6	6
006-111-00	Equalizer Nut	----	2	2	4	4
007-001-01	Equalizer Bolt	----	2	2	4	4
007-007-00	Keeper Bolt	2	4	4	6	6
007-017-00	Spring Eye Bolt	2	4	4	6	6
013-004-00	Equalizer	----	2	----	4	----
013-044-01	Equalizer	----	----	2	----	4

§ For 33.5" axle spacing

‡ For 36" axle spacing

## Slipper Springs

	Single A/P-103-00	Tandem A/P-202-00 <sup>§</sup> A/P-216-00 <sup>‡</sup>	Triple A/P-302-00 <sup>§</sup> A/P-316-00 <sup>‡</sup>
A	24.0	----	----
B	----	28.8	30.4
C	----	33.5	36.0
D	11.5	11.5	11.5
E	----	----	33.0

**Note:** All 2" wide slipper springs

§ For 33.5" axle spacing

‡ For 36" axle spacing

A, B, E – Hanger Spacing  
 C – Axle Spacing  
 D – Axle Location  
 H – Center of Spindle  
 Y – Frame Height  
 Z – Top of Tire to Bottom of Frame  
 SLR – Static Load Radius

To determine these values, contact your local sales engineer or distributor to run ProSpec™.

Some combinations of hangers and spring mountings may result in insufficient bump clearance. Refer to the Miscellaneous section for additional hanger kits, A/P kits, or other tires.

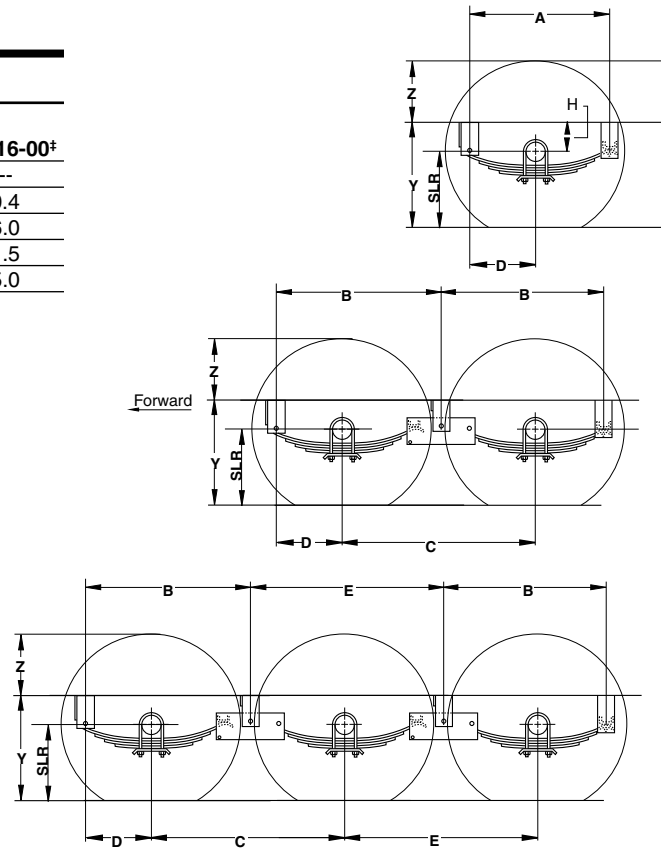

## D70 Overhang Per Side

	Min.	Max.
Straight	7.00"	9.00"
4" Drop	7.87"	9.00"

### Single Axles

require 1 HAP-105-00 kit

### Tandem Axles

require 1 HAP-105-00 kit and 1 HAP-205-01 kit

### Triple Axles

require 1 HAP-105-00 kit and 2 HAP-205-01 kits

## Rubber Bushed Suspension

Part No.	Description	Height	HAP-105-00	HAP-205-01
028-068-02	Front Hanger	5.50"	2	----
029-039-04	Center Hanger	4.50"	----	2
030-068-02	Rear Hanger	4.85"	2	----
006-011-00	5/16-18 UNC Locknut	----	2	2
006-038-00	5/8-11 UNC Locknut	----	2	2
006-112-00	1-8 UNC Locknut	----	----	2
007-007-00	Keeper Bolt	----	2	2
007-181-00	Spring Eye Bolt	----	2	2
007-182-00	Equalizer Bolt	----	----	2
013-117-03	Equalizer	----	----	2
059-200-00	Decal	----	1	1
059-203-00	Instruction Sheet	----	1	1

# 865 Hub Group

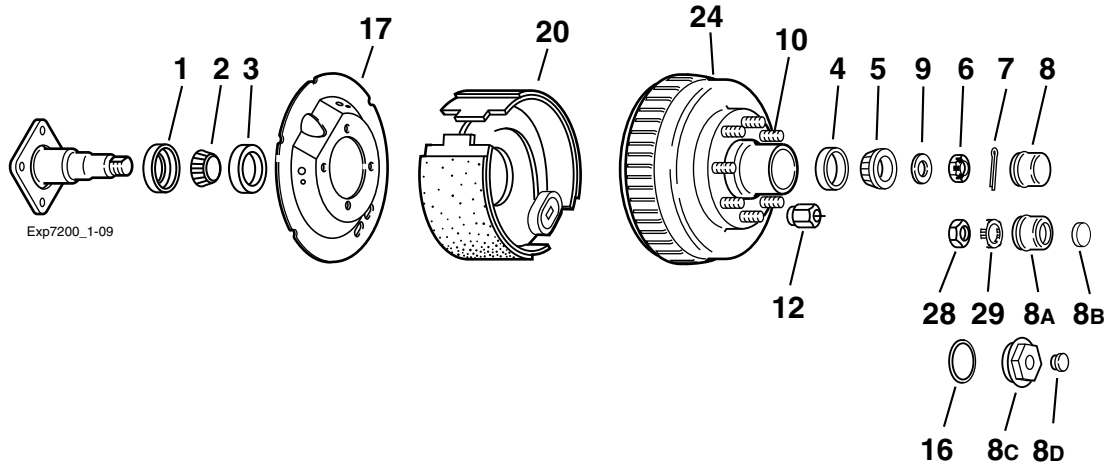

## Grease Lube Parts

Item	Part No.	Description
1	010-036-00	Seal
2	031-030-02	25580 Inner Bearing Cone
3	031-030-01	25520 Inner Bearing Cup
4	031-028-01	02420 Outer Bearing Cup
5	031-028-02	02475 Outer Bearing Cone
6	006-176-00	Spindle Nut
7	019-002-00	Cotter Pin (not used with E-Z Lube®)
8	021-039-00	Grease Cap
8A	021-043-01	Grease Cap for E-Z Lube®
8B	085-001-00	E-Z Lube® Rubber Plug
9	005-057-00	Spindle Washer
28	006-191-00	Special Jam Nut for E-Z Lube® (after 2002)
29	006-190-00	Spindle Nut Retainer for E-Z Lube® (after 2002)

## Oil Lube Parts

Item	Part No.	Description
1	010-063-00	Seal (Unitized)
2	031-030-02	25580 Inner Bearing cone
3	031-030-01	25520 Inner Bearing Cup
4	031-028-01	02420 Outer Bearing Cup
5	031-028-02	02475 Outer Bearing Cone
6	006-176-00	Spindle Nut
7	019-002-00	Cotter Pin
9	005-057-00	Spindle Washer
8C	021-035-00	Oil Cap
8D	046-032-00	Oil Cap Plug
ns	046-052-00	Oil Filler Plug (service part only)
16	010-045-00	'O' Ring for Oil Lube

## Studs & Wheel Nuts

Item	Part No.	Description
10	007-122-00	1/2-20 Press-in Stud
10	007-224-00	5/8-18 Press-in Stud
10	007-223-00	3/16-18-18 Press-in Stud
12	006-053-00	3/16-18 60° Cone Nut
12	006-109-00	5/8-18 90° Cone Nut
ns	006-058-00	5/8-18 Flange Nut

## Hubs

(After May 2000 for cast backing plate brakes)

Item	Part No.	Description	Bolt Circle
24	008-393-10	Grease 1/2" Stud	8 on 6.50
24	008-393-04	Grease 3/16" Stud	8 on 6.50
24	008-393-06	Grease 5/8" Stud	8 on 6.50
24	008-393-09	Oil 1/2" Stud	8 on 6.50
24	008-393-03	Oil 3/16" Stud	8 on 6.50
24	008-393-05	Oil 5/8" Stud	8 on 6.50

## Brakes

(After May 2000 with cast backing plate brakes)

Item	Part No.	Description
17	036-118-20	Dust Shield not included with brake assembly
20	K23-429-00	RH 12 1/4" x 2 1/2" Electric Brakes
20	K23-428-00	LH 12 1/4" x 2 1/2" Electric Brakes

## Service Parts Not Interchangeable With Cast Parts

## Hubs

(Before May 2000 for stamped backing plate brakes)

Item	Part No.	Description	Bolt Circle
24	008-355-13	Grease 3/16" Stud	8 on 6.50
24	008-355-15	Grease 5/8" Stud	8 on 6.50
24	008-355-12	Oil 3/16" Stud	8 on 6.50
24	008-355-14	Oil 5/8" Stud	8 on 6.50

## Brakes

(Before May 2000 with stamped backing plate brakes)

Item	Part No.	Description
17	036-110-00	Dust Shield (top) included with brake assembly
17	036-110-01	Dust Shield (bottom) included with brake assembly
20	K23-369-00	RH 12 1/4" x 2 1/2" Electric Brakes
20	K23-370-00	LH 12 1/4" x 2 1/2" Electric Brakes

ns - not shown

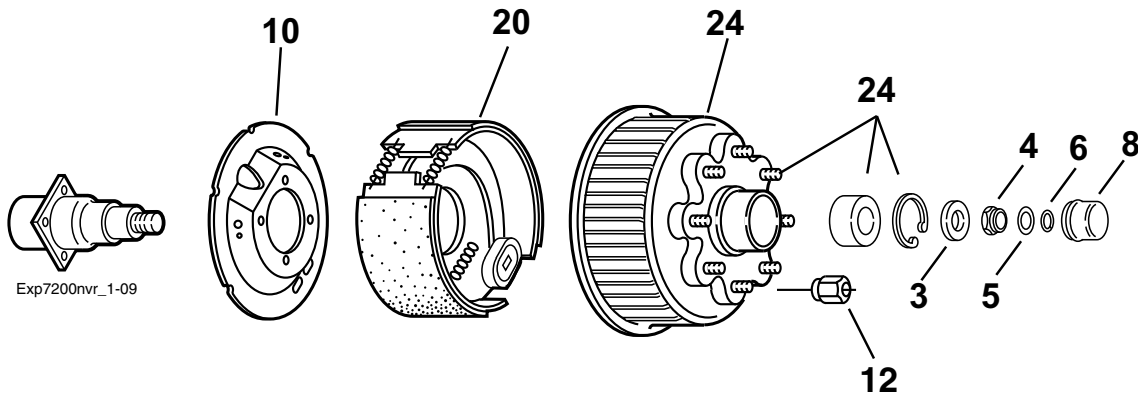

### Nev-R-Lube® Parts 50MM

Item	Part No.	Description
3	005-149-00	Spindle Washer
4	006-183-00	Spindle Nut
5	092-002-00	Washer, Torque Label
6	069-096-00	Snap Ring
8	021-086-00	Grease Cap

### 12¼" x 2½" Brakes

Item	Part No.	Description
10	036-118-20	Dust Shield
20	K23-428-00/K23-429-00	LH/RH Manual Adjust Electric Brake

### Hubs With Bearing and Wheel Studs

Item	Part No.	Description	Bolt Circle
24	008-395-80	Hub and Drum includes: 007-223-00 9/16" Press-in Studs 031-071-03 50mm Bearing Cartridge 069-093-00 Bearing Retainer	8 on 6.50
ns	008-395-81	Hub and Drum includes: 007-224-00 5/8" Press-in Studs 031-071-03 50mm Bearing Cartridge 069-093-00 Bearing Retainer	8 on 6.50

### Wheel Nuts

Item	Part No.	Description
12	006-053-00	9/16-18 60° Cone Nut
ns	006-109-00	5/8-18 90° Cone Nut
ns	006-058-00	5/8-18 Flange Nut

ns - not shown

# 12¼" x 2½" Electric Brake – Cast Backing Plate



CSA approved at 7100#/14.2 SLR

**7200 LBS. CAPACITY**

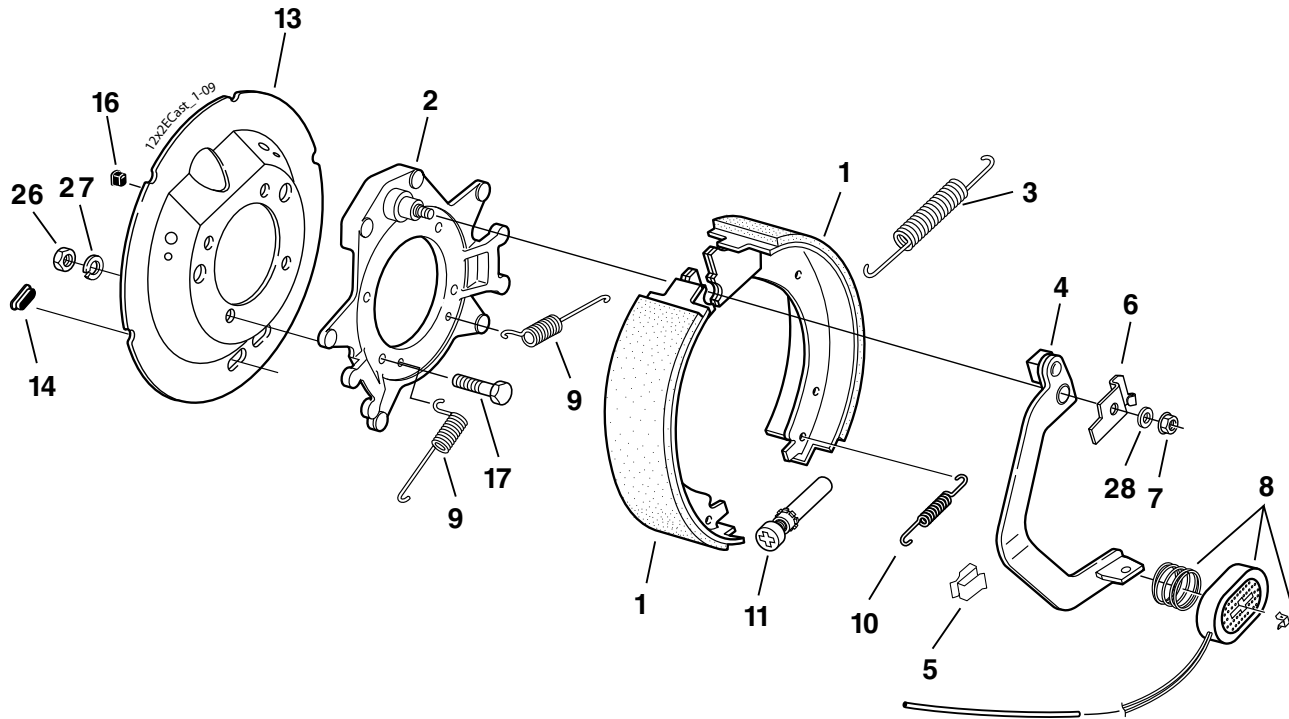

## Electric Brake

Item	Part No.	Qty/Brk	Description
0	K23-428-00	1	LH Complete Brake Assembly (shown)
0	K23-429-00	1	RH Complete Brake Assembly
1	K71-497-00	1	LH Shoe & Lining Kit Contains: 1 #040-348-01 LH Primary Shoe & Lining 1 #040-349-02 LH Secondary Shoe & Lining
1	K71-496-00	1	RH Shoe & Lining Kit Contains: 1 #040-349-01 RH Primary Shoe & Lining 1 #040-348-02 RH Secondary Shoe & Lining
2	036-119-02	1	Backing Plate
3	046-119-00	1	Shoe Return (gray)
4	047-124-05	1	LH Actuating Lever Arm Assembly
4	047-125-05	1	RH Actuating Lever Arm Assembly
5	027-039-00	3	Wire Clip
6	071-455-01	1	LH Lever Arm Retainer
6	071-455-02	1	RH Lever Arm Retainer
7	006-092-01	1	Flange Nut
8	K71-441-00	1	Magnet Kit Contains: 1 #042-136-00 Magnet 1 #027-050-00 Magnet Retainer 1 #046-117-00 Magnet Spring
9	046-136-00	2	Centering Spring
10	046-018-00	1	Adjuster Spring (red)
11	048-017-00	1	Adjuster Assembly
*13	036-118-20	1	Dust Shield (sold separately)
*14	046-007-00	2	Adjuster Slot Plug
*16	046-016-00	1	Magnet Wire Grommet
*17	007-251-00	4	Brake Mounting Bolt
*26	006-129-00	4	Hex Nut
*27	005-058-00	4	Lock Washer
28	005-142-00	1	Washer

\* Not included with complete brake assembly. Item sold separately.

**Brakes manufactured after May 2000 use the cast backing plate**

# 12¼" x 2½" Electric Brake – Stamped Backing Plate



Service Parts Only

CSA approved at 7100#/14.2 SLR

7200 LBS. CAPACITY

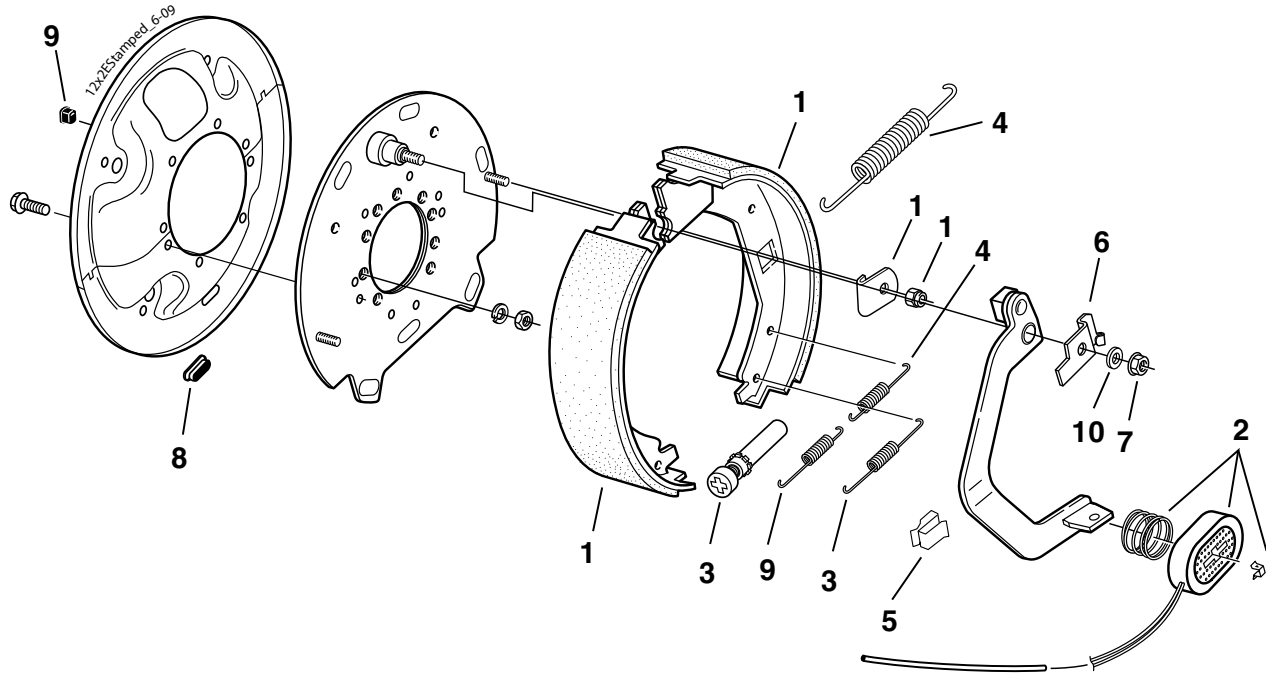

## Electric Brake – Service Parts Only

Item	Part No.	Qty/Brk	Description
0	K23-369-00	1	RH Complete Brake Assembly (shown)
0	K23-370-00	1	LH Complete Brake Assembly
1	K71-410-00	1	Shoe & Lining Kit Contains: 1 #040-310-01 RH Primary S&L or LH Secondary S&L 1 #040-309-01 LH Primary S&L or RH Secondary S&L 2 #005-107-00 Shoe Hold Down Washer 2 #006-127-00 Locknut
2	K71-441-00	1	Magnet Kit Contains: 1 #042-136-00 Magnet 1 #027-050-00 Magnet Retainer 1 #046-117-00 Magnet Spring
3	K71-411-00	1	Adjusting Screw Kit Contains: 1 #046-018-00 Adjuster Spring (red) 1 #046-017-00 Adjuster Assembly
4	K71-412-00	1	Brake Spring Kit Contains: 1 #046-119-00 Shoe Return (gray) 1 #046-117-00 Magnet Spring 2 #046-120-00 Centering Spring 1 #046-018-00 Adjuster Spring (red)
5	027-039-00	3	Wire Clip
6	071-455-01	1	LH Lever Arm Retainer
6	071-455-02	1	RH Lever Arm Retainer
7	006-092-01	1	Flange Nut
8	046-007-00	2	Adjuster Slot Plug
9	046-016-00	1	Magnet Wire Grommet
10	005-142-00	1	Washer

Note: Only numbered items are available.

**Brakes manufactured before May 2000 use the stamped backing plate**



# AIRFLEX® Light Trailer Suspension System



7200 LBS. CAPACITY

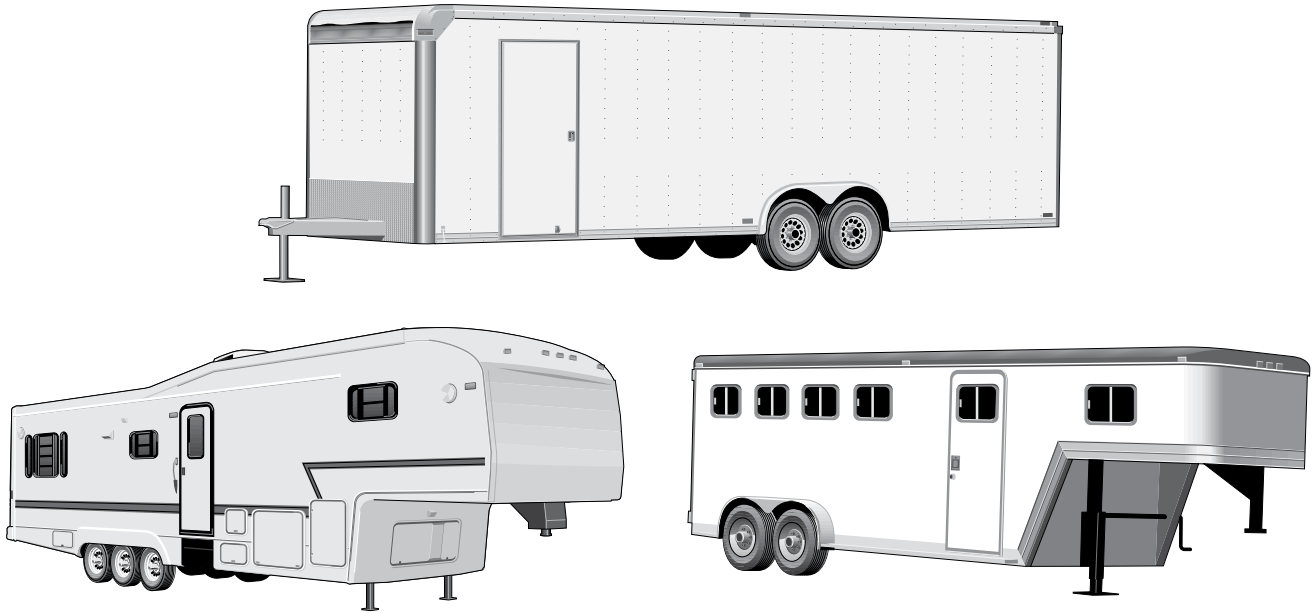

## Smooth Out the Roughest Roads

- Soft Ride – New hybrid suspension combines air and rubber torsion for an excellent ride
- Independent – Ride and stability improve with independent wheel action
- Equalizing – Axle-to-axle load equalization allows use on triple axle trailers
- Reliable – Rubber cushions ride even if air is not available
- Maintains constant ride height for the ultimate ride
- Fully assembled for easy installation
- Adjustable axle alignment feature
- Available for single, tandem or triple axle applications
- Optional ride height control valve and air generation kits are available
- 2 year limited warranty

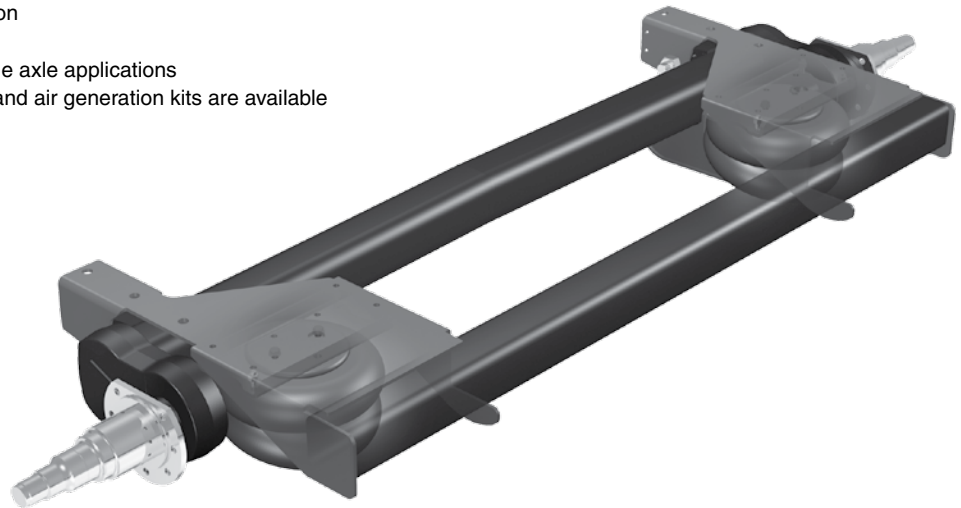

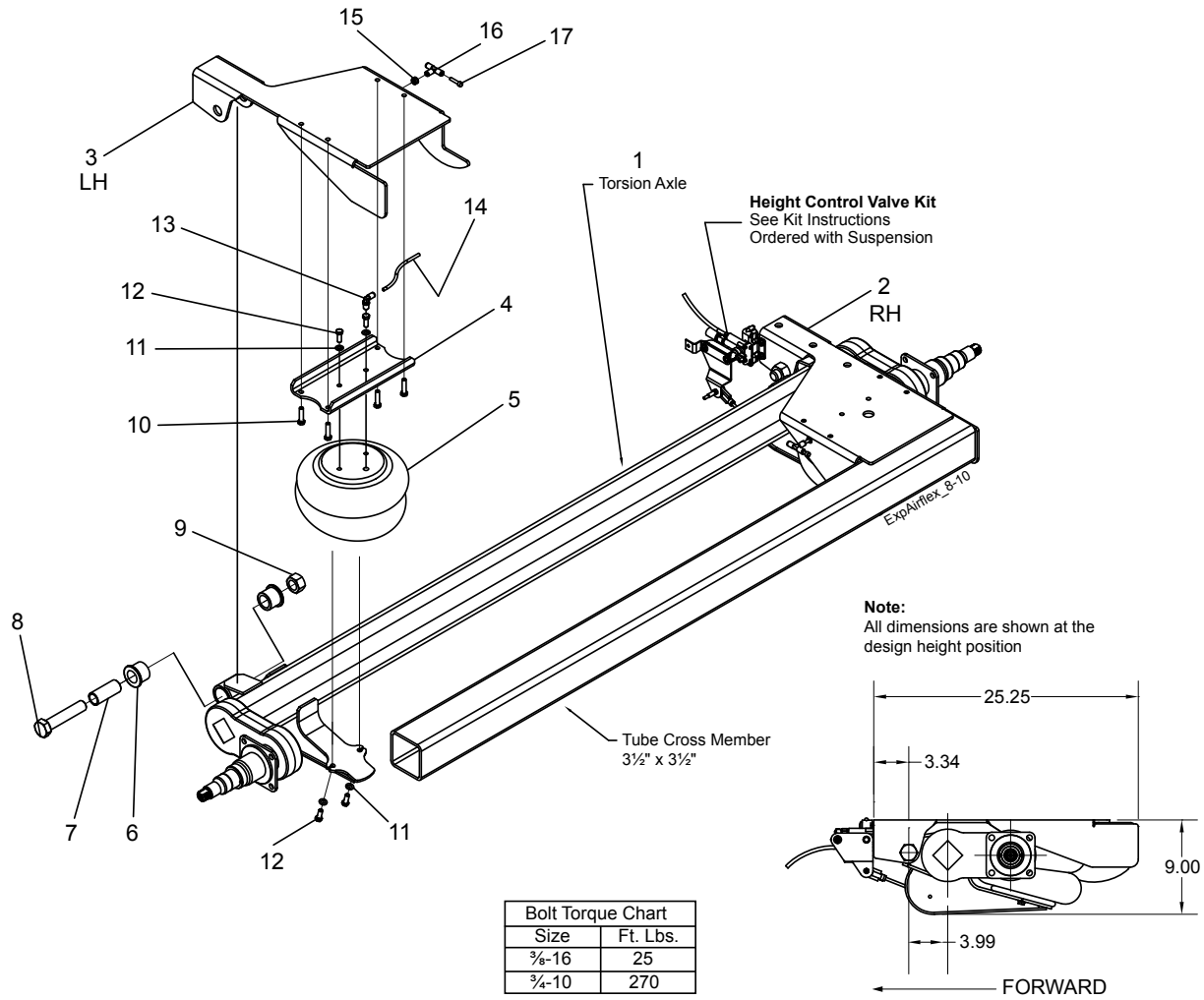

### AIRFLEX® Suspension Components 7200#

Item	Part No.	Qty/Axle	Description
1	n/a	1	Torsion Axle with Suspension Brackets
2	003-327-00	1	RH Frame Bracket
3	003-326-00	1	LH Frame Bracket
4	003-323-00	2	Channel, Air Spring Support
5	W01-358-6947	2	Firestone Air Spring
6	014-123-00	2	Pivot Bushing Kit
7	014-127-00	2	Bushing Spacer/Liner
8	n/a	2	3/4-10 UNC x 4.5" LG HHCS
9	n/a	2	3/4-10 UNC Stover Lock Nut
10	n/a	8	3/8-16 UNC x 1.5" LG HHCS
11	n/a	8	3/8 Regular Split Lock Washer
12	n/a	8	3/8-16 UNC x 1" LG HHCS
13	n/a	2	1/4 NPTM x 1/4 T 90° Elbow, Swivel
14	n/a	2	1/4 x 6.25" LG Nylon Tube
15	n/a	2	Grommet
16	n/a	2	1/4 T Union Tee
17	n/a	2	1/4 T Plug

n/a - not available